



The Mediating Role of Cognitive Flexibility in the Effect of Empathic Tendency on Teacher Professionalism

Zülbiye KAÇAY¹, Nuri Berk GÜNGÖR², Fikret SOYER³

ARTICLE INFO

Article History:

Received 08.06.2020

Received in revised form

12.08.2020

Accepted 12.11.2020

Available online

27.01.2021

ABSTRACT

The aim of the study was to determine whether cognitive flexibility had a mediating role in the effect of empathic tendencies of physical education and sports teachers on their professionalism. Empathic Tendency, Teacher Professionalism and Cognitive Flexibility Scales were used in the study with personal information form. A total of 283 physical education and sports teachers, 85 (30%) female and 198 (70%) male, voluntarily participated in the study. In the analysis of data, The Shapiro-Wilk normality test was used to determine if data set had a normal distribution or not. Kaiser-Mayer-Olkin (KMO) coefficient and Bartlett test were used to determine the suitability of the data for factor analysis. The theoretically created model was tested with a structural equation model. In the study, descriptive statistics were used in order to determine the average scores obtained from the scales. AMOS and SPSS package programs were used for analysis of data set. It was determined that the participants' Empathic Tendency, Professionalism and Cognitive Flexibility levels were high. Also, all variables were determined to have a significant correlation between each other. It was determined that all variables positively affected each other, empathic tendency predicted both cognitive flexibility and teacher professionalism at certain rates (40%-28%), and cognitive flexibility had a mediating role in the relationship between empathic tendency and teacher professionalism. As a result, multifaceted and effective studies that will increase the empathic tendency and cognitive flexibility levels should be carried out.

© 2021 IJPES. All rights reserved

Keywords:

Empathic tendency, cognitive flexibility, teacher professionalism, sports

1. Introduction

Educational institutions can be defined as places that act as an intermediary in the transfer of knowledge, skills, behavior and values to future generations by teachers, and in this context, individuals are educated and raised (Kaçay, 2015). The social contribution of sports and sports activities to create a young, dynamic and healthy generation cannot be ignored (Kaçay & Soyer, 2020, p. 3). Physical education and sports classes aim to raise awareness of individuals about exercise and sports activities from an early age, and to play sports and sports activities a part of the individual's life (Güngör, 2019, pp. 2-3). Teachers, on the other hand, are the biggest part of the change and they are representatives who help students reach their goals and prepare them for life (Kaçay, Soyer, & Eskiler, 2015, p. 115). In this context, physical education and sports teachers have an important role in ensuring that the culture and values of the society are sustainable, and sports can take place in the life of the individual. When evaluated in this respect; a quality education equals the presence of qualified teachers. As an indicator of being qualified, teacher professionalism stands out.

Expressed by the researchers as a professional value, an ideology specific to a company or institution, professionalism is defined as the level of excellence or competence an individual demonstrates in their work. Professionalism is a concept that includes the ability to cooperate and communicate effectively with colleagues, the awareness of responsibility, not to be indifferent to the interests, needs and expectations of

¹Çanakkale Onsekiz Mart University, Faculty of Sports Sciences, Çanakkale, Turkey (zzkacay@gmail.com)

²Karamanoğlu Mehmetbey University, Faculty of Sports Sciences, Karaman, Turkey (nuriberkgungor@gmail.com)

³Balıkesir University, Faculty of Sports Sciences, Balıkesir, Turkey (fikretsoyer@gmail.com)

others and being able to behave towards others as they wish to be treated, knowing that they are a part of the whole (Salem Press Encyclopedia, 2020).

The concept of professionalism, which has been researched and interpreted by different disciplines specific to their fields in the literature, is generally associated with the management approach. However, this approach is controlling and restrictive, unlike the inclusive and collaborative educator professionalism (Osgood, Gordon, & Philips, 2010). The quality of the services provided is an indicator of the professionalism of the experts in their fields (Mackey & Evans, 2011, p. 20). When evaluated from this point of view, the quality of education and qualified student profile emerges as an indicator of teacher professionalism. Tschannen-Moran (2009) has reported that professionalism is an important element in increasing the quality of education and improving student quality.

Educational institutions that undertake the training of the next generation, therefore teachers, as the most important element of the education system, contribute to the increase of the welfare level of the society with the students who are the output of this system, the transfer of social values to the next generations and the country to reach the level of modern civilization. So, there is a need for teacher professionalism that expresses specialization in the field and being able to transfer the knowledge and skills in the best way.

The main purpose of teacher professionalism is to complete an effective and successful education process in mutual respect, love, loyalty, harmony and cooperation (Hoy, Smith & Sweetland, 2002; Hoy & Sabo, 1998). In order to achieve this, it is important to be a teacher who listens and understands effectively in communication with students and colleagues and can be a role model with his attitudes and behaviors. The effective transfer of information and emotions depends on the high empathic tendency. Because if the individual can put himself in the place of the other person, he will be able to understand his feelings and thoughts better and support him better.

Empathy is trying to see the events through the eyes of the other person without judging and questioning (Dökmen, 2011). In this case, the individual who thinks he is being understood opens up more easily, feels better (Günay, 2019, p. 3), feels more love, respect and trust towards the person who understands him (Kuzgun, 2006). This situation contributes to effective and efficient learning. Because students feel more comfortable with a teacher who understands, values and behaves friendly and they try to avoid situations that may cause problems and want to be more successful. On the other hand, empathic understanding not only positively affects relationships with students but also interactions with the social environment and colleagues (Duru, 2002, p. 24), contributing to more qualified social relationships, and thus to higher job satisfaction and performance. In this context, it is thought that empathic tendency will contribute positively to teacher professionalism.

Cognitive flexibility is defined as the capacity to exhibit flexible and adaptable behaviors against the changes happening in the environment (Siegel, 2001, p. 87). In addition, it is emphasized that cognitive flexibility is the ability of an individual to control himself and his environment (Phalet & Kosic, 2006, p. 340). In short, cognitive flexibility, which is defined as the ability to adapt to changing conditions (Güngör, 2019, p. 21), refers to the ability to think and act in a versatile way and to produce different solutions to problems; It can be said that it is a variable that contributes to the ability of teachers to understand and support others more easily, thanks to their knowledge, skills and experience and the level of empathic tendency they have in all situations and conditions. Therefore, the aim of the study is to determine whether cognitive flexibility has a mediating role in the effect of empathic tendencies of physical education and sports teachers on their professionalism. Determining the extent to which empathic tendency and cognitive flexibility predict and affect teacher professionalism can contribute to determining the variables that will affect or contribute to professionalism, and to include practices and policies that will improve professionalism. On the other hand, depending on the findings, it is thought that it can be a guide in terms of what can be focused on the development of teachers towards the solution of organizational problems that may arise due to low professionalism.

2. Method

2.1. Research Model and Hypotheses

The research was organized using the relational scanning model. Relational scanning model is used to determine the relationship between two or more variables and to obtain clues about cause and effect (Karasar,

2017). The model tested within the scope of the research was created by examining the relevant literature. This model was using structural equation modeling. The hypotheses of the model are expressed below.

H₁: Cognitive empathy affects teacher professionalism.

H₂: Emotional response affects teacher professionalism.

H₃: Social skills affect teacher professionalism.

H₄: Cognitive empathy affects cognitive flexibility.

H₅: Emotional response affects cognitive flexibility.

H₆: Social skills affect cognitive flexibility.

H₇: Cognitive flexibility affects teacher professionalism.

H₈: Cognitive flexibility has a mediating role in the relationship between empathic tendency and teacher professionalism.

2.2. Research Group

The study group of the research constituted physical education and sports teachers who work in the 2019-2020 academic year in seven different regions of Turkey. Within the scope of the research, the data were collected on an online platform. Since there was no missing or incorrect data among the collected data, all of them were used in the research. 85 (30%) of the participants are female and 198 (70%) of them are male. However, while 128 of participants (45.2%) were working in secondary school, 155 (54.8%) were working in any high school; 203 (71.7%) were undergraduate, 63 (22.3%) were graduate and 17 (6%) were doctoral program graduates. Also; 43 (15.2%) 1-5 years, 57 (20.1%) 6-10 years, 34 (12%) 11-15 years, 45 (15.9%) 16-20 years and 104 (36.7%) has 21 years or more of teaching experience. The average age of the participants was determined as 40.9 ± 7.8 .

2.3. Data Collection Tools

Empathic Tendency, Teacher Professionalism and Cognitive Flexibility Scales were used in the study with personal information form.

2.3.1. Empathic Tendency Scale

It was developed by Lawrence, Shaw, Baker, Baron-Cohen and David (2004) and adapted into Turkish language by Kaya and Çolakoğlu (2015). The scale was a 5- point likert type and consists of 13 items and 3 sub-dimensions in total. These sub dimensions are; expressed as cognitive empathy, emotional response, and social skills. The internal consistency coefficient of the scale; .86 for the general of the scale, .61 for social skills sub-dimension, .75 for emotional response sub-dimension, and .74 for cognitive empathy sub-dimension. The Cronbach Alpha coefficient obtained from the data set were determined as .80, .78, .71, .75, respectively.

2.3.2. Teacher Professionalism Scale

It was developed by Tschannen-Moran, Parish and Dipaola (2006) and adapted into Turkish language by Cerit (2012). The scale was a 5-point likert structure, consists of 8 items and one dimension. The higher the score obtained from the scale, the higher the level of teacher professionalism. The Cronbach Alpha coefficient of the original form of the scale was expressed as .90. The Cronbach Alpha coefficient obtained from the data set was .88.

2.3.3. Cognitive Flexibility Scale

Cognitive Flexibility Scale was developed by Martin and Rubin (1995) and adapted into Turkish language after completing its validity and reliability studies by Çelikkaleli (2014). The scale was a 6-point structure, consists of 12 items and one dimension. The high score that can be obtained from the scale indicates the high level of cognitive flexibility. The Cronbach Alpha coefficient of the original form of the scale was .80. The Cronbach Alpha coefficient obtained from the data set was determined as .77.

Confirmatory Factor Analysis Results of the Scales Used in the Scope of the Study

Table 1. Confirmatory factor analysis results of empathic tendency, teacher professionalism and cognitive flexibility scales

Model	Fit Index	Perfect Range	Acceptable Range	ETS	TPS	CFS
	X^2/sd	$0 < X^2/sd < 2$	$2 < X^2/sd < 5$	3.51	4.12	3.22
	RMSEA	$0.00 < RMSEA < 0.05$	$0.05 < RMSEA < 0.10$.07	.08	.08
	PGFI	$0.95 < PGFI < 1.00$	$0.50 < PGFI < 0.95$.61	.57	.61
	PNFI	$0.95 < PNFI < 1.00$	$0.50 < PNFI < 0.95$.66	.70	.64
	GFI	$0.90 < GFI < 1.00$	$0.85 < GFI < 0.90$.90	.93	.90
	AGFI	$0.90 < AGFI < 1.00$	$0.85 < AGFI < 0.90$.85	.87	.85
	CFI	$0.95 < CFI < 1.00$	$0.90 < CFI < 0.95$.91	.95	.93

ETS: Empathic Tendency Scale; TPS: Teacher Professionalism Scale; CFS: Cognitive Flexibility Scale

In order to test the construct validity of the Empathic Tendency Scale, multifactorial confirmatory factor analysis and to test the construct validity of the Teacher Professionalism and Cognitive Flexibility Scales the first-order confirmatory factor analysis was applied. Considering the suggestions of the AMOS package program, covariance assignments were performed between items 6 and 10 of the Cognitive Flexibility Scale and items 3 and 7 and 5, and 6 of the Teacher Professionalism Scale. As a result of the application of the proposed modifications, the goodness of fit index values produced by the model were shown in Table 1. Since the good values of fit in Table 1 provide the necessary conditions, it can be stated that the factor structures of the measurement tools used in the study were confirmed (Meydan & Şeşen, 2011).

2.4. Data Analysis

Before analyzing the data, it was checked whether there were missing or erroneous data in the data set. Then, it was examined whether the data set had a normal distribution or not. The Shapiro-Wilk normality test was applied, and it was concluded that the data set had a normal distribution by looking at the Kurtosis and Skewness values (Tabachnick & Fidell, 2013). Kaiser-Mayer-Olkin (KMO) coefficient and Bartlett test were used to determine the suitability of the data for factor analysis. According to the analysis result, KMO suitability coefficient was determined as .87 for the Empathic Tendency Scale, .88 for the Teacher Professionalism Scale, and .83 for the Cognitive Flexibility Scale. However, Bartlett test result was determined to be significant for the measurement tools included in the study ($p < .001$). Therefore, these values show the suitability of the data to factor analysis (Leech, Bartlett, & Morgan, 2005). The theoretically created model was tested with a structural equation model. In the study, descriptive statistics were used in order to determine the average scores obtained from the scales. AMOS and SPSS package programs were used for data analysis.

3. Results

This section includes the findings obtained by analyzing the data.

Table 2. Average scores of the participants from the empathic tendency scale

Scales	N	Min.	Max	\bar{x}	SD
Cognitive Empathy Sub-Dimension	283	1.20	5.00	4.08	.66
Emotional Response Sub-Dimension	283	1.00	5.00	4.32	.63
Social Skills Sub-Dimension	283	1.50	5.00	3.60	.53
Empathic Tendency Scale	283	1.23	4.77	4.01	.51

The average score the participants obtained from the Empathic Tendency Scale was determined as ($\bar{x} = 4.01$); From the "cognitive empathy" sub-dimension ($\bar{x} = 4.08$); "emotional response" sub-dimension ($\bar{x} = 4.32$) and the "social skills" sub-dimension ($\bar{x} = 3.60$).

Table 3. Average Scores that Participants obtained from Teacher Professionalism and Cognitive Flexibility Scales

Scales	N	Min.	Max.	\bar{x}	SD
Teacher Professionalism Scale	283	1.38	5.00	3.79	.70
Cognitive Flexibility Scale	283	2.92	6.00	4.81	.58

In Table 3, it was seen that the average score obtained by the participants from the Teacher Professionalism Scale ($\bar{x} = 3.79$) and the average score they got from the Cognitive Flexibility Scale ($\bar{x} = 4.81$).

Table 4. Investigation of the Relationship between Variables using the Pearson Moments Correlation

	CE	ER	SS	TP	CF
CE	1				
ER	.67**	1			
SS	.49**	.46**	1		
TP	.20**	.30**	.21**	1	
CF	.48**	.40**	.32**	.38**	1

CE: Cognitive Empathy; ER: Emotional Response; SS: Social Skills; TP: Teacher Professionalism; CF: Cognitive Flexibility

In Table 4, a positive and low-level relationship was determined between CE and TP. A moderate positive correlation was determined between CE with ER, SS and CF. A moderate positive correlation was determined between ER with SS, TP and CF. A low-level relationship was determined between SS and TP. A moderately positive relationship was determined between CF and TP.

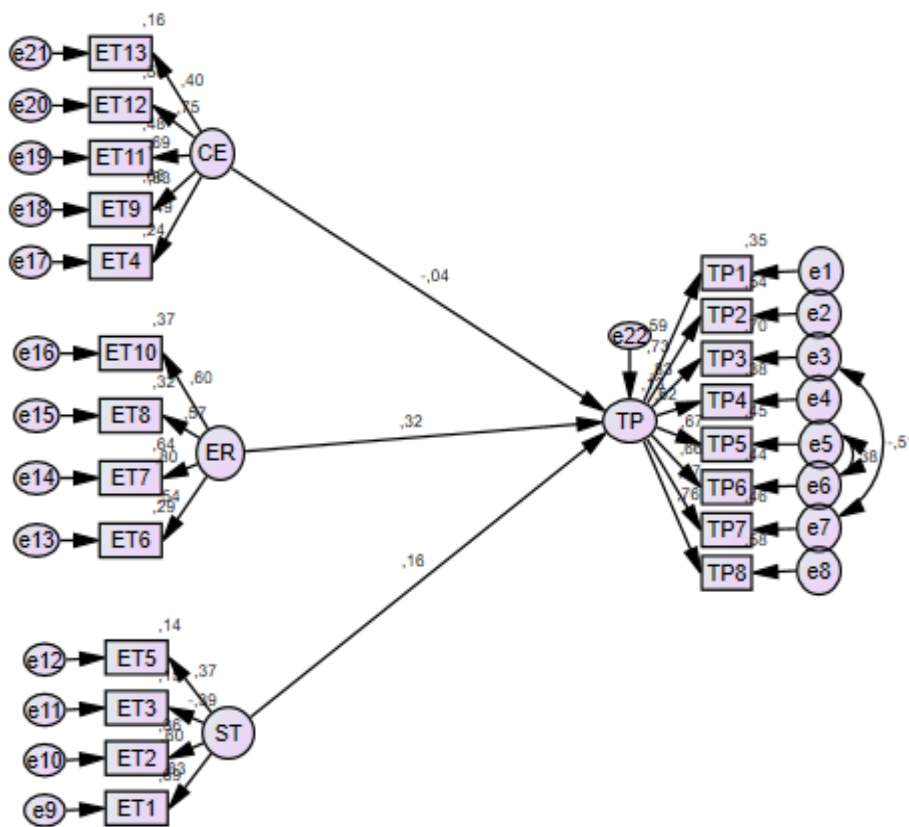

Figure 1. Structural equation model

It was seen that the standardized model in Figure 1 meets the necessary goodness of fit criteria ($\chi^2 / df = 3.85$, RMSEA = .07, PGFI = .70, PNFI = .66, GFI = .86, AGFI = .87, CFI = .90). By examining the goodness of fit index values of the model, the paths and parameter estimates in the model were discussed. Standardized β coefficients, standard error, critical ratio, p and R^2 values between variables according to the tested model are shown in the table below.

Table 5. Structural equation model coefficients

Variables		Standardize β	Std. Error	Critical Rate	p	R^2
Cognitive Emphaty	Teacher Professionalism	-.04	.07	-0.66	.50	.13
Emotional Respons		.32	.09	3.93	***	
Social Skill		.16	.05	2.18	.029	

Considering the analysis results; it can be stated that a statistically significant effect was determined in the relationship between emotional response and social skill with teacher professionalism, ($\beta_2 = .32$; $p < .05$; $\beta_3 = .16$; $p < .05$). There was no significant effect on the relationship between cognitive empathy and teacher

professionalism, ($\beta_1 = -.04$; $p > .05$). When the Squared Multiple Correlations (R^2) value of the model is considered; it can be seen that cognitive empathy, emotional response and social skills explain teacher professionalism at a rate of 13%.

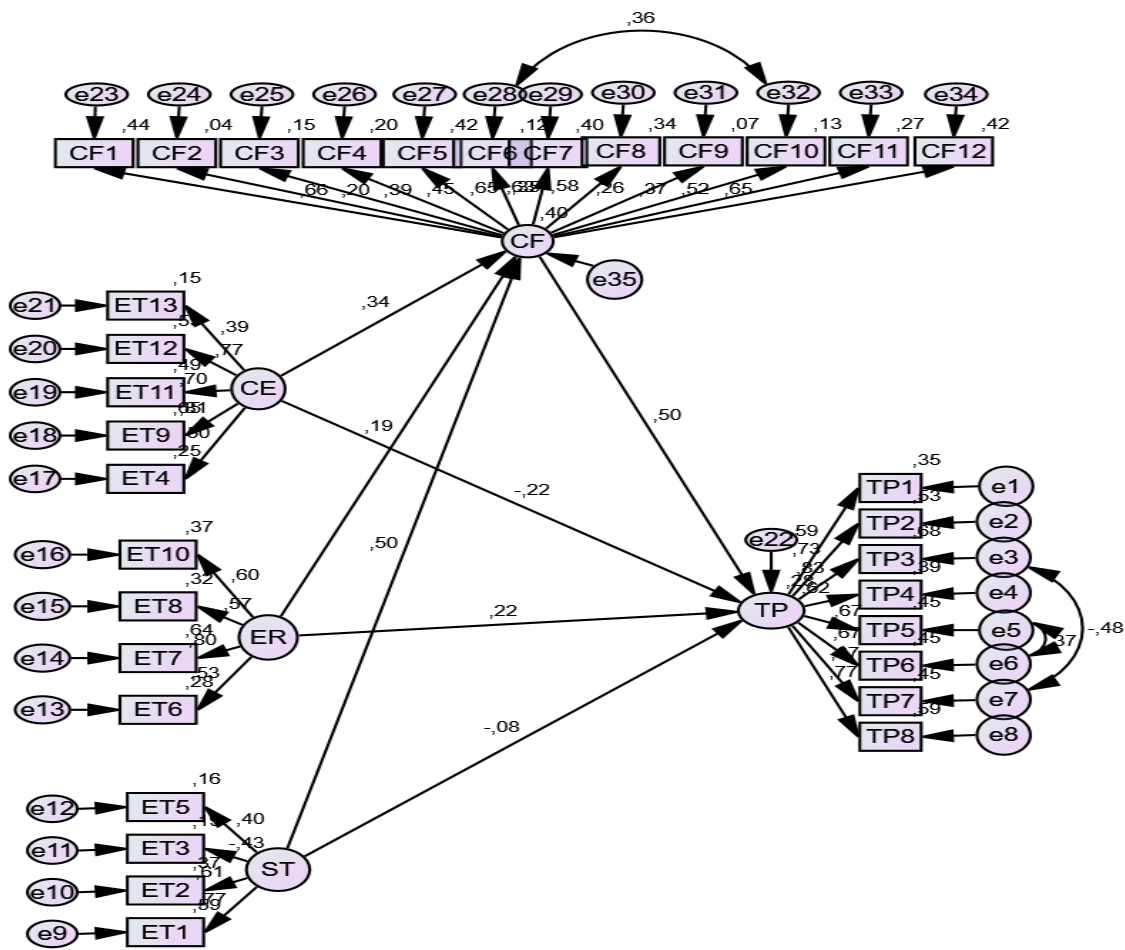

Figure 2. Internal and structural equation model of mediating variable

When the goodness of fit values of the model in Figure 2 were examined, it was seen that the necessary conditions are met ($\chi^2 / sd = 2.76$, RMSEA = .08, PGFI = .77, PNFI = .71, GFI = .88, AGFI = .86, CFI = .91). Standardized coefficients, standard error, critical ratio, p and R^2 values are shown in Table 6.

Table 6. Structural equation model coefficients tested by including the mediating variable

Variables		Standardize β	Standard Error	Critical Rate	P	R^2
Cognitive Emphaty		.34	.08	4.39	***	.40
Emotional Respons		.18	.07	2.68	.007	
Social Skill	Cognitive Flexibility	.50	.06	5.69	***	
Cognitive Flexibility	Teacher Professionalism	.50	.10	4.63	***	.28
Cognitive Emphaty		-.22	.08	-2.80	.005	
Emotional Respons	Teacher Professionalism	.22	.06	3.00	.003	
Social Skill		-.07	.10	-.86	.38	

When the analysis results were examined; it was determined that cognitive empathy, emotional response, and social skills affect cognitive flexibility ($\beta_4 = .34$; $p < .05$; $\beta_5 = .18$; $p < .05$; $\beta_6 = .50$; $p < .05$). Also, it was concluded that cognitive empathy, emotional response, and cognitive flexibility affected teacher professionalism ($\beta_1 = -.22$;

$p < .05$; $\beta_2 = .22$; $p < .05$; $\beta_7 = .50$; $p < .05$). It was determined that social skills did not affect teacher professionalism ($\beta_3 = -.07$; $p > .05$). From this point; while the hypotheses numbered 1, 2, 4, 5, 6, 7 of the research were accepted, the hypothesis 3 was not accepted.

Another hypothesis of the study is that it shows the mediating role of cognitive flexibility, empathic tendency and teacher professionalism. For the test of this hypothesis, the research method proposed by Baron and Kenny (1986) was taken as reference. According to the related study, the method consists of three stages. The first stage is the independent variable affects the dependent variable; in the second stage, independent variable affects the mediator variable; In the third and last stage, when the mediator variable is included in the first-stage model, the effects of the independent variable on the dependent variable are reduced and the mediating variable affects the dependent variable.

In line with this reference; when Table 5 was examined, it was concluded that emotional response and social skills affect teacher professionalism and the first stage conditions are met. Independent variables were also included in the other model in order to observe the change over the whole feature in the model while passing to the second stage. Considering Table 6; it was determined that cognitive empathy, emotional response and social skill affect cognitive flexibility, which is the mediator variable, and in the second stage, the conditions were met. By passing both stages, cognitive flexibility, which is the mediator variable, was included in the model and it was concluded that emotional responses effect decreases and the effect of social skills on teacher professionalism disappeared. Therefore, cognitive flexibility was found to have a mediating role in the effect of empathic tendency on teacher professionalism and the 8th hypothesis of the study was accepted.

Considering the Squared Multiple Correlations (R^2) value of the model, the cognitive flexibility of cognitive empathy, emotional response and social skill explain teacher professionalism at the rate of 40%; cognitive empathy, emotional response, social skills and cognitive flexibility at the rate of 28%.

4. Discussion and Conclusion

This study was conducted to determine whether cognitive flexibility had a mediating role in the effect of empathic tendencies of physical education and sports teachers on their professionalism. For this purpose, a total of 283 physical education and sports teachers, 85 (30%) female and 198 (70%) male, voluntarily participated in the study.

When the results of the analysis conducted in this context were examined, it was determined that the participants' Empathic Tendency, Professionalism and Cognitive Flexibility levels were found to be high when looking at the average scores obtained from these scales. In the sub-dimensions of empathic tendency, it was determined that teachers perceived themselves as adequate in the cognitive empathy dimension, this followed by emotional response and social skills dimensions.

In addition, when the sub-dimensions of empathic tendency, emotional response and social skills, affect teacher professionalism and the Squared Multiple Correlations (R^2) value of the Structural Equation Model is considered; It was determined that cognitive empathy, emotional response and social skills explain teacher professionalism by 13%.

When the literature is scanned, it can be seen that there are many studies the teacher professionalism is above the middle level or at high level (Cansoy & Parlar, 2017; Çelik, 2015; Güngör, 2019; Kılınc, 2014; Kılınc, Cemaloğlu & Savaş, 2015; Koşar, 2015; Moomaw, 2005;) and low level (Bayhan, 2011; Cerit, 2012). High level of professionalism indicate that the teachers are experts in their profession (Hess & Fennel, 2015), responsible and role model (Agezo, 2009), they do high quality works and qualified jobs (Hargreaves, 2000), teachers take active roles in education (Kılınc, 2014) and they can solve the problems in a creative and different way. (Carlgren, 1999). Keeping up with constantly renewed and changing needs has become a necessity in the rapidly globalizing new world order. In this respect, the high level of teacher professionalism can be considered as an indication that they are open to change and innovation, and that they fulfill their responsibilities in the best way by working in cooperation.

Those with high cognitive flexibility is known that they are attentive (Jonessen & Grobowski, 1993), investigative, questioning, self-confident individuals who can think analytically, do not have focus problems, are open to change and can produce different solutions (Martin & Anderson, 1998). Cognitive flexibility is

expressed as a concept that affects the level of social skills and contributes to effective communication and awareness raising (Stahl & Pry, 2005). On the other hand, social skills should be high in order to initiate and maintain effective communication and to display appropriate behavioral patterns in the face of problems. According to the findings of the study, it was determined that the social skill levels of physical education and sports teachers were high, and this affected the level of professionalism by 13%, together with cognitive empathy and emotional response as a variable contributing to teacher professionalism. In parallel with this study, Güngör (2019) found that physical education and sports teachers' cognitive flexibility and professionalism levels are above average and individual innovativeness also affects teacher professionalism.

According to analysis results, it was determined that cognitive empathy, emotional response and social skills affected the cognitive flexibility; It was determined that cognitive empathy, emotional response, and cognitive flexibility affected teacher professionalism. It was determined that social skills did not affect teacher professionalism. From this point; While the hypotheses 1, 2, 4, 5, 6, 7 of the research were accepted (H1: Cognitive empathy affects teacher professionalism; H2: Emotional response affects teacher professionalism; H4: Cognitive empathy affects cognitive flexibility; H5: Emotional response H6: Social skills affect cognitive flexibility; H7: Cognitive flexibility affects teacher professionalism), Hypothesis number 3 (H3: Social skill affects teacher professionalism) was not accepted. Finally, when Table 5 is examined, it was determined that cognitive flexibility (ability to predict knowledge, apply to unusual situations) had a mediating role in the effect of empathic tendency on teacher professionalism, and the hypothesis of the research number 8 (H8: Cognitive flexibility has a mediating role in the relationship between empathic tendency and teacher professionalism) was accepted. In addition, considering the Squared Multiple Correlations (R^2) value of the model, the cognitive flexibility of cognitive empathy, emotional response and social skill explain teacher professionalism at the rate of 40%; cognitive empathy, emotional response, social skills and cognitive flexibility at the rate of 28%.

Based on these findings, it was determined that all variables positively affected each other, empathic tendency predicted both cognitive flexibility and teacher professionalism at certain rates (40% / 28%), and cognitive flexibility had a mediating role in the relationship between empathic tendency and teacher professionalism. As a result, it can be said that as the empathic tendency and cognitive flexibility levels of teachers increase, their professionalism levels also increase. Although there is no research directly examining the empathic tendency and its effect on professionalism in the literature, there are studies that examine its relationship with different variables (William, 2006; Stripling, 2019). Çetinkaya Ulusoy and Paslı Gürdoğan (2019) also found that nurses' empathic tendency levels affect colleague solidarity. There are also studies conducted to determine the factors affecting teacher professionalism positively and negatively (negatively: Overbaugh, 1990).

According to Cha (2014), the level of interaction with children, parents and those in the institution also how much importance they attach to their own development and their love for children are factors affecting teacher professionalism. As a result of this study, it was concluded that empathic tendency positively affected teacher professionalism and cognitive flexibility mediated this. Güngör (2019) in his study investigating the mediating role of cognitive flexibility in the effect of individual innovation on teacher professionalism, concluded that cognitive flexibility does not affect professionalism. There are also studies that investigate the mediating role of cognitive flexibility in different variables (Cardom, 2016; Lin, Tsai, Lin, & Chen, 2014; Yu, Yu, & Lin, 2019) and find it as a mediator.

The research findings showed that the empathic tendency that supports the establishment of positive relationships and the cognitive flexibility levels, that helps to adapt to the changing situations easily and enables to produce solutions with different perspectives by thinking versatile, were important in order to maintain a high level of professionalism whose main purpose is to complete an effective and successful education and training process in mutual respect, love, loyalty, harmony and cooperation. Therefore; the general result of this research is the need to carry out multifaceted and effective studies that will increase the empathic tendency and cognitive flexibility levels, which are determined as some of the elements that will develop and support teachers' professionalism, and that teacher training should be organized to include these.

In this study the sample group was a physical education and sports teachers but in future studies sample group can be broadened and comparisons among different groups can be researched. In order to improve the empathic tendency of the teachers, educations and applications can be used by the administrations.

5. References

- Agezo, C. K. (2009). School reforms in Ghana: A challenge to teacher quality and professionalism. *IFE Psychologia: An International Journal*, 17(2), 40-64. doi:10.4314/ifep.v17i2.45302
- Baron, R. M., & Kenny, D. A. (1986). The moderator–mediator variable distinction in social psychological research: Conceptual, strategic, and statistical considerations. *Journal of Personality and Social Psychology*, 51(6), 1173.
- Bayhan, G. (2011). *Öğretmenlerin profesyonelliğinin incelenmesi* (Yayımlanmamış doktora tezi). Marmara Üniversitesi Eğitim Bilimleri Enstitüsü, İstanbul.
- Cansoy, R., & Parlar, H. (2017). Examining the relationships between the level of schools for being professional learning communities and teacher professionalism. *Malaysian Online Journal of Educational Sciences*, 5(3), 13-27.
- Cardom, R. D. (2016). *The mediating role of cognitive flexibility on the relationship between cross-race interactions and psychological well-being* (Doctoral dissertation). The University of Kentucky, Kentucky.
- Carlgren, I. (1999). Professionalism and teachers as designers. *Journal of Curriculum Studies*, 31(1), 43-56. doi:10.1080/002202799183287
- Cerit, Y. (2012). Okulun bürokratik yapısı ile sınıf öğretmenlerinin profesyonel davranışları arasındaki ilişki. *Kuram ve Uygulamada Eğitim Yönetimi [Educational Administration: Theory and Practice]*, 18(4), 497-521
- Çelik, M. (2015). *Öğretmenlerin mesleki profesyonelliği ile tükenmişlikleri arasındaki ilişki* (Yüksek lisans tezi). Dumlupınar Üniversitesi Eğitim Bilimleri Enstitüsü, Kütahya.
- Çelikkaleli, Ö. (2014). Bilişsel Esneklik Ölçeği'nin geçerlik ve güvenilirliği. *Eğitim ve Bilim*, 39(176), 339-346.
- Çetinkaya Uslusoy, E, Paslı Gürdoğan, E. (2019). Hemşirelerde empatik eğilim meslektaş dayanışmasını etkiliyor mu? *Adnan Menderes Üniversitesi Sağlık Bilimleri Fakültesi Dergisi*, 3(1), 19-29. Retrieved from <https://dergipark.org.tr/tr/pub/amusbfd/issue/42985/481032>
- Dökmen, Ü. (2011). *Sanatta ve günlük yaşamda iletişim çatışmaları ve empati*. Remzi.
- Duru, E. (2002). Öğretmen adaylarında empatik eğilim düzeyinin bazı psikososyal değişkenler açısından incelenmesi. *Pamukkale Üniversitesi Eğitim Fakültesi Dergisi*, 2(12), 21–35.
- Günay, M. (2019). *Beden eğitimi öğretmenlerinin empatik eğilimleri ile öğrencilerinin öğretmene yönelik yakınlık algısı arasındaki ilişkinin incelenmesi* (Yayımlanmamış yüksek lisans tezi). Marmara Üniversitesi, Eğitim Bilimleri Enstitüsü, İstanbul.
- Güngör, N. B. (2019). *Beden eğitimi ve spor öğretmenlerinin bireysel yenilikçilik düzeyinin öğretmen profesyoneliğine olan etkisinde bilişsel esnekliğin aracılık rolü* (Yayımlanmamış doktora tezi). Gazi Üniversitesi, Eğitim Bilimleri Enstitüsü, Ankara.
- Hargreaves, A. (2000). Four ages of professionalism and professional learning. *Teachers and Teaching: Theory and Practice*, 6(2), 151-182.
- Hess, F. M., & Fennell, M. (2015). Point-counterpoint: Teacher professionalism. *Kappa Delta Pi Record*, 51(4), 159. doi:10.1080/00228958.2015.1089618
- Hoy, W. K., & Sabo, D. J. (1998). *Quality middle schools: Open and healthy*. Thousand Oaks, CA: Corwin.
- Hoy, W. K., Smith, P. A., & Sweetland, S. R. (2002). The development of the organizational climate index for high schools: Its measure and relationship to faculty trust. *The High School Journal*, 86(2), 38-49.
- Jonassen, D. H. & Grabowski, B. (1993). *Handbook of individual differences, learning and instruction*. Lawrence Erlbaum Associates.
- Kaçay, Z. (2015). *Beden eğitimi öğretmenlerine göre okul yöneticilerinin etik liderlik davranışlarının örgütsel bağlılık ve yaşam doyumuna etkisi* (Yayımlanmamış yüksek lisans tezi). Sakarya Üniversitesi, Sosyal Bilimler Enstitüsü, Sakarya.

- Kaçay, Z. ve Soyer, F. (2020). İş yeri yılmazlığının yordayıcıları örgütsel güven, lider-üye etkileşimi ve iş yeri maneviyatı. *LAP LAMBERT Academic Publishing* (2020-05-21).
- Kaçay, Z., Soyer, F. & Eskiler, E. (2020). Analysis of the ethical leadership behaviors' effect on life satisfaction and mediation effect of organizational commitment. *Khazar Journal of Humanities and Social Sciences*, 23(1), 114-123. DOI: 10.5782/2223-2621.2020.23.1. 114
- Karasar, N. (2017). *Bilimsel araştırma yöntemi: Kavramlar ilkeler teknikler*. Nobel.
- Kaya, B., & Çolakoğlu, Ö. (2015). Empati düzeyi belirleme ölçeği (EDBÖ) uyarlama çalışması. *İnönü Üniversitesi Eğitim Fakültesi Dergisi*, 16(1), 17-30. doi: 10.17679/iuefd.16127895
- Kılınç, A. Ç., Cemaloğlu, N., & Savaş, G. (2015). The relationship between teacher leadership, teacher professionalism, and perceived stress. *Eurasian Journal of Educational Research*, 58, 1-26.
- Kılınç, A.Ç. (2014). Öğretmen profesyonelizminin bir yordayıcısı olarak okul kültürü. *Eğitim ve Bilim*, 39, 105-118.
- Koşar, S. (2015). Öğretmen profesyonelizminin yordayıcıları olarak okul müdürüne güven ve öz yeterlik. *Eğitim ve Bilim*, 40(181), 255-270.
- Kuzgun, Y. (2006). *İlköğretimde rehberlik*, Nobel.
- Lawrence, E. J., Shaw, P., Baker, D., Baron-Cohen, S., & David, A. S. (2004). Measuring empathy: Reliability and validity of the empathy quotient. *Psychological Medicine*, 34(5), 911-920. doi: 10.1017/S0033291703001624
- Leech, N. L., Barrett, K. C., & Morgan, G. A. (2005). *SPSS for intermediate statistics: Use and interpretation*. Psychology Press.
- Lin, W. L., Tsai, P. H., Lin, H. Y., & Chen, H. C. (2014). How does emotion influence different creative performances? The mediating role of cognitive flexibility. *Cognition & Emotion*, 28(5), 834-844.
- Mackey, J., & Evans, T. (2011). Interconnecting networks of practice for professional learning. *The International Review of Research in Open and Distributed Learning*, 12(3), 1-18.
- Martin, M. M., & Anderson, C. M. (1998). The cognitive flexibility scale: Three validity studies. *Communication Repots*, 11, 1-9.
- Martin, M. M., & Rubin, R. B. (1995). A new measure of cognitive flexibility. *Psychological Reports*, 76(2), 623-626.
- Meydan, C. H., & Şeşen, H. (2011). *Yapısal eşitlik modellemesi AMOS uygulamaları*. Detay.
- Moomaw, W. & Pearson, L. C. (2005). The relationship between teacher autonomy and stress, work satisfaction, empowerment, and professionalism. *Educational Research Quarterly*, 29(1), 38-54.
- Osgood, J., Gordon, V., & Philips, J. (2010). Municipal clerks: Examining a model of job satisfaction. *Public Personnel Management*, 39(4), 327-352.
- Phalet, K., & Kotic, A. (2006). Acculturation in European societies. In D. Sam & J.W. Berry (eds), *The Cambridge handbook of acculturation psychology* (pp. 331-348). CUP
- Siegel, D. J. (2001). Toward an interpersonal neurobiology of the developing mind: Attachment, "mindsight", and neural integration. *Infant Mental Health Journal*, 22, 67-94
- Stahl, L., & Pry, R. (2005). Attentional flexibility and perseveration: Developmental aspects in young children. *Child Neuropsychology*, 11(2), 175-189.
- Tabachnick, B. G., & Fidell, L. S. (2013). *Using multivariate statistics*. California State University.
- Tschannen-Moran, M., Parish, J., & DiPaola, M. F. (2006). School climate and state standards: How interpersonal relationships influence student achievement. *Journal of School Leadership*, 16, 386-415.
- Tschannen-Moran, M., Parish, J., & DiPaola, M. F. (2006). School climate and state standards: How interpersonal relationships influence student achievement. *Journal of School Leadership*, 16, 386-415.

Yu, Y., Yu, Y., & Lin, Y. (2019). Anxiety and depression aggravate impulsiveness: the mediating and moderating role of cognitive flexibility. *Psychology, Health & Medicine*, 1-12.