



www.ijpes.com

ISSN: 2148-9378



# Development, Validity and Reliability Study of the Play Preferences Scale (PPS) for Children Receiving Preschool Education\*

Songül ÖZGENEL<sup>1</sup>, İsa KAYA<sup>2</sup>

<sup>1</sup> Ministry of National Education, İstanbul, Türkiye 0009-0004-0943-5593

<sup>2</sup> Faculty of Education, Fatih Sultan Mehmet Vakıf University, İstanbul, Türkiye 0000-0003-3604-1368

## ARTICLE INFO

### Article History

Received 01.11.2023

Received in revised form  
10.01.2024

Accepted 25.01.2024

Article Type: Research  
Article



## ABSTRACT

The aim of the study is to develop a Likert-type scale to determine the play preferences of children attending pre-school education. The research was designed and carried out according to the survey research model. Data collected from 3 different study groups were used in the scale development process. The study groups consist of parents of children attending pre-school education in İstanbul Province in the 2022-2023 academic year. The 33-item and 8-dimensional structure obtained after EFA was also confirmed with CFA. Dimensions were determined as solitary play, parallel play, together play, collaborative play, building-building play, dramatic play, games with rules and digital play. It is seen that the reliability coefficients of the scale after EFA and CFA vary between 0.757 and 0.900. In order to distinguish between the lower and upper groups and to make comparisons between the groups, an independent group t test was performed, and it was revealed that there was a difference between the 27% lower and 27% upper groups ( $p < .05$ ). It was determined that the test-retest values of the game type preferences scale were significant. According to these values, it was determined that the scale gave consistent results. When all studies were evaluated, it was concluded that the play preferences scale is a measurement tool that can validly and reliably measure the play preferences of children receiving preschool education.

Keywords:

Play preferences, play, scale development, pre-school

## 1. Introduction

Play, which is at the center of a child's life, affects all areas of the child's development either directly or indirectly. Play contributes to the child's physical, mental and social development and plays an important role in personality development (Santrock, 2017; Slavin, 2019). In his book *Emile*, Rousseau states that the way to provide appropriate education to the child is through play. At the same time, it emphasizes the developing and educational aspect of the game, stating that children can play all day long and that the game prepares the child for life (Kaya, 2018). Play, which is one of the most basic needs after the need for love (Başaran, 2011; Gürpınar, 2006), improves children's creative thinking and decision-making skills (Atay, 2017).

A play is a voluntary action in which the player participates willingly, with or without rules, takes place in a certain time and place, has a purpose, creates a feeling of tension and joy, and creates a space different from the real world (Huizinga, 2021). Piaget expressed the game as "harmony" (Yavuzer, 1999). Huizinga (2021) states that situations that are not considered possible in real life come to life in the fictional spaces created by the play. It creates a beautiful space in the chaos of life. Play provides freedom and learning space for the child. The child has the opportunity to try and reinforce what he has learned, heard and seen through play (Yörükoğlu, 1978).

\* This study was produced from Songül Özgenel's master's thesis under the supervision of Assoc. Prof. İsa Yıldırım.

Corresponding author's address: Ministry of National Education, İstanbul, Türkiye

e-mail: [ozgenelsongul@hotmail.com](mailto:ozgenelsongul@hotmail.com)

**Citation:** Özgenel, S. & Kaya, İ. (2024). Development, validity and reliability study of the play preferences scale (PPS) for children receiving preschool education. *International Journal of Psychology and Educational Studies*, 11(1), 66-79. <https://doi.org/10.52380/ijpes.2024.11.1.1327>

Classification of the play, which is a comprehensive and complex process, has been made in various ways. Classifications can be made according to developmental stages, including games based on social interaction, plays based on application, and play based on playgrounds (Ünsal, 2020). According to another classification, plays based on action are classified as plays based on discovery, plays based on imagination, plays based on emotion and deception, and imitation plays (Bacanlı, 2018). Parten (1932) observed children during play, examined children's level of participation in peer plays, and classified plays according to social participation levels (Trawick-Smith, 2018). Parten classified children's plays under six headings: effortless play, spectator play, solitary play, parallel play, together play and cooperative play. Although Parten stated that play types may vary depending on age, he also stated that play behaviors in the preschool period may occur as different play types at different times. Piaget suggests that children's play behaviors are shaped from simple to complex depending on cognitive development (Metin Aslan, 2013). According to Piaget, play involves the child's desire to explore and experience what is around him and is an element that supports cognitive development (Bardak & Topaç, 2021). Piaget classified play in three ways; practical play (practice play), symbolic play and play with rules. Smilansky made classifications based on Piaget's play stages and defined children's plays as; classified it into four groups as functional play, structure-building play, dramatic play, and play with rules (Şen, 2014; Ünsal, 2020). Although play classifications are not separated by a clear line, it is stated that each child can sometimes return to the spectator, sometimes alone, and sometimes parallel play steps and go back and forth between plays (Berk, 2020; Metin Aslan, 2013; Trawik-Smith, 2018).

Apart from Smilansky and Parten's classifications, today various plays have emerged through technological devices such as computers, tablets and mobile phones. These games are called digital games. Digital games, which entered our lives as a society in the early 1980s, have become a part of the daily lives of many people, young and old, with the development of technology in recent years (Bayındır & Mısırlı, 2020). Digital games are preferred by children because they are colorful, active and interesting, and there is an increase in children's habits of spending time in front of the screen and playing with technological devices.

When the literature is examined, many studies are found examining the effects of play on children's cognitive, behavioral, emotional, social, language, physical/psycho-motor development areas (Akgül, 2021; Ata, 2016; Barnet & Storm, 1981; Çakan, 2021; Dowdell, Graya, & Maloneb, 2011; Gölge, 2022; Koçyiğit & Başara Baydilek, 2020; Leseman, Rollenberg, & Rispens, 2001; Metin Aslan, 2013; Sandseter, 2009; Smith, 1978; Tuzcuoğlu et al., 2020; Yıldırım, 2022). In addition, there are studies that examine children's play behaviors with different variables (Coplan et al., 2001; Gmitrova et al., 2009; Güngören, 2022; Kalkusch et al., 2021; Özdemir, 2014; Özdemir, 2019; Rubin et al., 1978; Tuğrul et al., 2019; Uygun & Kozikoğlu, 2019; Yokuş and Yavuz Konokman, 2019). However, it has been determined that data collection tools are limited regarding which plays children prefer. Based on this, the current study aimed to develop a valid and reliable scale to determine the play preferences of preschool children.

## **2. Methodology**

### **2.1. Research Model**

In the research, a Likert-type scale development study was conducted to determine the play preferences of children attending pre-school education and to measure them in a valid and reliable way. The research was designed and carried out according to the survey research model. The survey model is a research model designed to determine certain characteristics of individuals (Büyüköztürk et al., 2012).

### **2.2. Study Groups**

The study groups of the research consist of parents of children attending pre-school education in Pendik District of Istanbul Province in the 2022-2023 academic year. The data was collected face to face by the researcher by visiting 12 preschools. The study group was determined according to the convenience sampling method. Convenience sampling is a type of sampling that is "non-probability or non-random that meets certain practical criteria, such as easy accessibility to members of the population, geographical proximity, availability or willingness at a particular time" (Dörnyei & Taguchi, 2009). During the scale development process, data was collected from 3 different study groups. In scale development research, when deciding on the size of the study group, 5 to 10 times the number of items is generally taken into consideration (MacCalum et al., 1999 cited in Erkuş, 2014). Since there are 46 items in the draft scale form, data were collected from 444

parents for Exploratory Factor Analysis (EFA), 454 parents for Confirmatory Factor Analysis (CFA), and 60 parents for criterion validity and test-retest analysis.

*Study Group 1:* The first study group of the research consists of 444 parents whose children receive pre-school education for EFA. 53.7% of the children are girls and 46.3% are boys. 88.8% of the participants are mothers and 29.7% are high school graduates. 51.1% of the participating parents have 2 children.

*Study Group 2:* The second study group of the research consists of 454 parents whose children receive pre-school education for CFA. 49.3% of the children are girls and 50.7% are boys. 90% of the participants are mothers, and 34.5% of the mothers have a bachelor's degree. 52.7% of participating parents have 2 children.

*Study Group 3:* The third study group of the research consists of 60 parents to provide evidence for the criterion validity and test-retest study of the game preferences scale. 55% of the children are girls and 45% are boys. 96.7% of the participants are mothers and 36.7% of the mothers are high school graduates. 51.7% of participating parents have 2 children.

### 2.3. Scale Development Process

The development of a new scale stems from a need. It is seeing the shortcomings and inadequacies of existing scales or wondering what a new variable is like (Erkuş, 2014; Seçer, 2015). The lack of a scale to determine the play preferences of preschool children led us to develop a new scale. For the scale development study, the steps suggested by Devellis (2014) were followed. The stages are as follows; clearly determining the structure to be measured, creating the item pool, and determining the measurement method; expert review of the initial item pool; consider the inclusion of validity clauses; applying the items to the scale development sample, evaluating the items; is to optimize the scale length.

For the content validity of the scale, firstly, the literature on play classification, play types and child play development was scanned (Bacanlı, 2018; Bardak & Topaç, 2021; Berk, 2020; Bredekamp, 2015; Durualp & Aral, 2017; Trawick-Smith, 2018; Sevinç, 2009). Particularly in the literature, Parten and Smilansky's classification was emphasized and an item pool suitable for two classifications was created. 10 parents whose children were receiving pre-school education were interviewed, and questions were asked to the parents about the plays their children played. In the interviews with parents, since parents stated that their children were especially interested in digital games, items related to digital games were added to the item pool in addition to Parten and Smilansky's play classification. An item pool of 49 items was created in line with the literature review and parental opinions. The draft scale form was sent to 7 experts who conduct academic research in the field of pre-school education and the concept of play. Experts were asked to evaluate the items as "appropriate", "needs to be corrected", "not suitable" and "suggestion", arrangements were made in line with expert opinions and a draft scale form consisting of 46 items was created (Lawshe, 1975). The content validity rate of the draft scale was calculated with the "Lawshe Technique" formula. According to this formula,  $KGO = [NG/(N/2)] - 1 = 0.962$ . According to this ratio, it can be said that the content validity rate of the draft scale is sufficient. A pilot study was conducted on 30 parents, the target audience, to determine whether the items in the draft scale form were understandable. After the pilot study, the draft scale was finalized and the data collection process began.

PENN Interactive Peer Play Scale was used to provide evidence for the criterion validity of the Play Preferences Scale. It evaluates children's competencies and needs in play in order to identify children who demonstrate successful peer relationships and those who have difficulty establishing relationships with their peers (Penn Early Childhood and Family Research Center, 2023). PENN Interactive Peer Play Scale was developed by Fantuzzo (1998) and adapted into Turkish by Camgöz (2010).

### 2.4. Analysis of Data

Data collected from 3 different study groups were used in the scale development process. Kaiser-Meyer-Olkin (KMO) and Bartlett's Test of Sphericity, exploratory factor analysis (EFA) and item-total correlation analyzes were conducted for the validity of the Play Type Preferences Scale with the data collected from the first study group (444). Confirmatory Factor Analysis (CFA) and correlation analyzes were conducted for criterion validity with the data collected from the second study group (454). To decide the validity of the CFA model, fit indices were examined ( $\chi^2/df$ , RMR, SRMR, GFI, AGFI, IFI, TLI, CFI, RMSEA). For reliability, Cronbach's

Alpha Reliability coefficient was calculated after EFA and CFA, 27% Lower-Upper Groups independent groups t-test was performed for item discrimination, and test-retest analyzes were performed for consistency.

## 2.5. Ethical

Permission was received from Fatih Sultan Mehmet Vakıf University Scientific Research and Publication Ethics Board to collect data (31/03/2023-271).

## 3. Findings

### 3.1. Validity Findings

Factor analysis was performed to determine the construct validity of the Play Preferences Scale. To evaluate the suitability of the collected data for factor analysis, normality (kurtosis and skewness) (Table 1), Kaiser-Meyer-Olkin (KMO) and Bartlett's Test of Sphericity values were examined (Table 1).

**Table 1.** Normality Values of the Data Set

| Dimensions                 | Mean  | Sd   | Kurtosis | Skewness |
|----------------------------|-------|------|----------|----------|
| Digital game               | 1.822 | .949 | .094     | -.353    |
| Solitary oyun              | 2.115 | .805 | -.081    | -.186    |
| Parallel                   | .602  | .736 | 1.252    | 1.419    |
| Together play              | 3.025 | .592 | -.543    | .695     |
| Cooperative oyun           | 3.095 | .600 | -.440    | .027     |
| Building-construction play | 2.857 | .787 | -.521    | .027     |
| Dramatic play              | 2.227 | .941 | -.279    | -.470    |
| Play with rules            | 2.302 | .795 | -.156    | .223     |

When Table 1 is examined, it is seen that the kurtosis and skewness values of the play types are between  $\pm 1.5$ . It is suggested that the skewness and kurtosis values of the data being within  $\pm 2$  may be sufficient for normality (George and Mallery, 2016). According to this criterion, it was concluded that the data showed normal distribution.

In the analysis of the scale, Parten and Smilansky's classification and digital game data were analyzed separately, but the findings are given in the same tables. KMO and Bartlett's test results for play types are given in Table 2.

**Table 2.** Kaiser-Meyer-Olkin (KMO) and Bartlett Sphericity Test Values

|                               | Parten                   | Smilansky | Dijital Game |
|-------------------------------|--------------------------|-----------|--------------|
| KMO                           | ,898                     | ,842      | ,859         |
| Chi-Square ( $\chi^2$ )       | 3116,666                 | 1245,357  | 1245,357     |
| Bartlett's Test of Sphericity | df (Serbestlik derecesi) | 10        | 10           |
|                               | Sig. (Anlamlılık)        | ,000      | ,000         |

As seen in Table 2, the KMO values of the data obtained from the draft scale form were 0.898, 0.842 and 0.859, respectively, and Bartlett's test was found to be significant ( $p < .001$ ). According to Tavşancıl (2002), a KMO value of 0.80 and above indicates that the data is suitable for factor analysis. Exploratory Factor Analysis was conducted to determine the factor structure of the scale. Factor analysis started with Principal Components Analysis. In the first analysis, the factors with eigenvalues (eigenvalue) of the scale above 1 and the variances and percentages explained by these factors are given in Table 3.

**Table 3.** Eigenvalues of the Scales and Amounts of Variance Explained in the First Analysis

| Classification                  | Factor    | Eigenvalue | Variance | Cumulative |
|---------------------------------|-----------|------------|----------|------------|
| Parten's play classification    | 1. factor | 7,204      | 28,816   | 28,816     |
|                                 | 2. factor | 3,378      | 13,513   | 42,329     |
|                                 | 3. factor | 1,773      | 7,093    | 49,422     |
|                                 | 4. factor | 1,256      | 5,024    | 54,445     |
|                                 | 5. factor | 1,114      | 4,454    | 58,900     |
| Smilansky's play classification | 1. factor | 5,084      | 31,774   | 31,774     |
|                                 | 2. factor | 2,234      | 13,961   | 45,736     |
|                                 | 3. factor | 2,203      | 13,768   | 59,504     |
| Digital game                    | 1. factor | 3,493      | 69,853   | 69,853     |

When Table 3 is examined, it is seen that there are 5 factors with eigenvalues above 1 in the first analysis of Parten's classification. The total variance explained by 5 factors is 54.445%. The eigenvalue of the first factor is 7.204 and the variance it explains is 28.816%. In the first analysis of Smilansky's classification, there are 3 factors with eigenvalues above 1. The total variance explained by 3 factors is 59.504%. The eigenvalue of the first factor is 5.084 and the variance it explains is 31.774. The factor of the digital game is one-dimensional, its eigenvalue is 3.493 and the variance it explains is 69.853%.

In the Principal Components Analysis, the item load cutoff point was accepted as .50. Since item load values contribute significantly to the variance explained by the factor in factor analysis, the Varimax orthogonal rotation technique is recommended to ensure that the item load is at least 0.32 and above and to determine the distribution of items to factors (Tabachnick & Fidell, 2007). In the Principal Components Analysis, the factor distributions of the items were examined, and the items with factor loadings below 0.50, as well as those with item loads less than 0.10 among the items overlapping more than one factor, were removed one by one and the analysis was repeated. The extracted items are shown in Table 4.

**Table 4.** *Extracted Items and Item Extraction Criteria*

| Classification                  | Factor    | Reasons for Substance Removal |                                 |
|---------------------------------|-----------|-------------------------------|---------------------------------|
|                                 |           | Low Factor Load               | Item Combining Multiple Factors |
| Parten's play classification    | 1. factor | 41                            |                                 |
|                                 | 2. factor | 12                            | 14,                             |
|                                 | 3. factor | 3, 5,                         |                                 |
|                                 | 4. factor |                               | 6, 7, 8                         |
| Smilansky's play classification | 1. factor |                               |                                 |
|                                 | 2. factor | 29,                           | 30                              |
|                                 | 3. factor | 25, 26                        | 28                              |
| Digital game                    | 1. factor |                               |                                 |

When Table 4 is examined, it is seen that 13 items out of 46 were removed in the factor analysis. It is seen that items 3, 5, 12, 25, 26, 29 and 41 were removed because their item loads were below 0.50. In addition, it was understood that items 6, 7, 8, 14, 28 and 30 loaded on more than one factor and were removed because the load values between the factors were less than 0.10.

After the item extraction process is completed, the eigenvalues and variance percentages of the scale are presented in Table 5.

**Table 5.** *Eigenvalues of the Scales and Amounts of Variance Explained in the Final Analysis*

| Classification                  | Factor    | Eigenvalue | Variance | Cumulative |
|---------------------------------|-----------|------------|----------|------------|
| Parten's play classification    | 1. factor | 5,747      | 33,809   | 33,809     |
|                                 | 2. factor | 2,235      | 13,150   | 46,958     |
|                                 | 3. factor | 1,377      | 8,102    | 55,061     |
|                                 | 4. factor | 1,116      | 6,564    | 61,625     |
| Smilansky's play classification | 1. factor | 4,198      | 38,168   | 38,168     |
|                                 | 2. factor | 1,835      | 16,679   | 54,847     |
|                                 | 3. factor | 1,758      | 15,980   | 70,827     |
| Digital game                    | 1. factor | 3,493      | 69,853   | 69,853     |

When Table 5 is examined, after the item removal process for Parten's classification, 4 factors with eigenvalues above 1 emerged. The total variance explained by 4 factors is 61.625%. The eigenvalue of the first factor is 5.747 and the variance it explains is 33.809%. In the first analysis of Smilansky's classification, there are 3 factors with eigenvalues above 1. The total variance explained by 3 factors is 70.827%. The eigenvalue of the first factor is 4.198 and the variance it explains is 38.168. The factor of the digital game is one-dimensional, its eigenvalue is 3.493 and the variance it explains is 69.853%.

After the item extraction process, Varimax orthogonal rotation technique was used to determine the distribution of the items to the factors, the distribution of the items to the factors was examined and the factors were named (Table 6).

**Table 6.** Factor Loadings of the Items

| Items                 | Parten   |                |          |               | Smilansky             |          | Digital    |                |
|-----------------------|----------|----------------|----------|---------------|-----------------------|----------|------------|----------------|
|                       | Solitary | Parallel       | Together | Collaborative | Building-construction | Dramatic | With rules | Digital game   |
| i1                    | 0,844    |                |          |               |                       |          |            |                |
| i2                    | 0,873    |                |          |               |                       |          |            |                |
| i4                    | 0,727    |                |          |               |                       |          |            |                |
| i9                    |          | 0,841          |          |               |                       |          |            |                |
| i10                   |          | 0,869          |          |               |                       |          |            |                |
| i11                   |          |                | 0,624    |               |                       |          |            |                |
| i13                   |          |                | 0,525    |               |                       |          |            |                |
| i15                   |          |                | 0,660    |               |                       |          |            |                |
| i16                   |          |                | 0,684    |               |                       |          |            |                |
| i17                   |          |                | 0,731    |               |                       |          |            |                |
| i18                   |          |                |          |               | 0,818                 |          |            |                |
| i19                   |          |                |          |               | 0,870                 |          |            |                |
| i20                   |          |                |          |               | 0,847                 |          |            |                |
| i21                   |          |                |          |               | 0,820                 |          |            |                |
| i22                   |          |                |          |               | 0,810                 |          |            |                |
| i23                   |          |                |          |               |                       | 0,857    |            |                |
| i24                   |          |                |          |               |                       | 0,854    |            |                |
| i27                   |          |                |          |               |                       | 0,750    |            |                |
| i31                   |          |                |          |               |                       |          | 0,761      |                |
| i32                   |          |                |          |               |                       |          | 0,874      |                |
| i33                   |          |                |          |               |                       |          | 0,826      |                |
| i34                   |          |                |          | 0,622         |                       |          |            |                |
| i35                   |          |                |          | 0,642         |                       |          |            |                |
| i36                   |          |                |          | 0,736         |                       |          |            |                |
| i37                   |          |                |          | 0,602         |                       |          |            |                |
| i38                   |          |                |          | 0,770         |                       |          |            |                |
| i39                   |          |                |          | 0,788         |                       |          |            |                |
| i40                   |          |                |          | 0,621         |                       |          |            |                |
| i42                   |          |                |          |               |                       |          |            | 0,832          |
| i43                   |          |                |          |               |                       |          |            | 0,834          |
| i44                   |          |                |          |               |                       |          |            | 0,889          |
| i45                   |          |                |          |               |                       |          |            | 0,796          |
| i46                   |          |                |          |               |                       |          |            | 0,824          |
| <b>Total variance</b> |          | <b>%61,625</b> |          |               | <b>%70,827</b>        |          |            | <b>%69,853</b> |

When Table 6 is examined, as a result of the factor analysis for Parten's game classification, the Lone Game factor load values are between .727 and .873; Parallel Game factor loading values are .841 to .869; Play Together factor loading values are .525 to .731; Cooperative Play factor loading values range between .602 and .788. As a result of the factor analysis for Smilansky's game classification, the Building-Construction Game factor load values are between .810 and .870; Dramatic Play factor loading values are .750 to .857; Rules of Play factor loading values vary between .761 and .874. Digital Game item load values range between .796 and .889.

Since 13 items were removed from the scale in factor analysis, the order of the items changed. For this reason, the new order of the items and their distribution into factors are presented in Table 7.

**Table 7.** Distribution of Post-EFA Items According to Play Types

| Classification                  | Play types            | Distribution of Substance  | Number of items |
|---------------------------------|-----------------------|----------------------------|-----------------|
| Parten's play classification    | Solitary              | 1, 2, 3                    | 3               |
|                                 | Parallel              | 4, 5                       | 2               |
|                                 | Together              | 6, 7, 8, 9, 10             | 5               |
|                                 | Collaborative         | 22, 23, 24, 25, 26, 27, 28 | 7               |
| Smilansky's play classification | Building-construction | 11, 12, 13, 14, 15         | 5               |
|                                 | Dramatic              | 16, 17, 18                 | 3               |
|                                 | With rules            | 19, 20, 21                 | 3               |
| Digital game                    | Digital               | 29, 30, 31, 32, 33         | 5               |

After determining the distribution of the items to the factors, the correlation values between the items and the factor they belong to were calculated and shown in Table 8.

**Table 8.** Item-Total Correlation Values

|     | Solitary | Parallel | Together | Collaborative | Building-construction | Dramatic | With rules | Digital game |
|-----|----------|----------|----------|---------------|-----------------------|----------|------------|--------------|
| i1  | ,846**   |          |          |               |                       |          |            |              |
| i2  | ,878**   |          |          |               |                       |          |            |              |
| i3  | ,743**   |          |          |               |                       |          |            |              |
| i4  |          | ,916**   |          |               |                       |          |            |              |
| i5  |          | ,929**   |          |               |                       |          |            |              |
| i6  |          |          | ,695**   |               |                       |          |            |              |
| i7  |          |          | ,700**   |               |                       |          |            |              |
| i8  |          |          | ,751**   |               |                       |          |            |              |
| i9  |          |          | ,729**   |               |                       |          |            |              |
| i10 |          |          | ,705**   |               |                       |          |            |              |
| i11 |          |          |          |               | ,813**                |          |            |              |
| i12 |          |          |          |               | ,869**                |          |            |              |
| i13 |          |          |          |               | ,843**                |          |            |              |
| i14 |          |          |          |               | ,856**                |          |            |              |
| i15 |          |          |          |               | ,851**                |          |            |              |
| i16 |          |          |          |               |                       | ,843**   |            |              |
| i17 |          |          |          |               |                       | ,857**   |            |              |
| i18 |          |          |          |               |                       | ,798**   |            |              |
| i19 |          |          |          |               |                       |          | ,788**     |              |
| i20 |          |          |          |               |                       |          | ,874**     |              |
| i21 |          |          |          |               |                       |          | ,835**     |              |
| i22 |          |          |          | ,594**        |                       |          |            |              |
| i23 |          |          |          | ,778**        |                       |          |            |              |
| i24 |          |          |          | ,746**        |                       |          |            |              |
| i25 |          |          |          | ,696**        |                       |          |            |              |
| i26 |          |          |          | ,833**        |                       |          |            |              |
| i27 |          |          |          | ,796**        |                       |          |            |              |
| i28 |          |          |          | ,743**        |                       |          |            |              |
| i29 |          |          |          |               |                       |          |            | ,829**       |
| i30 |          |          |          |               |                       |          |            | ,833**       |
| i31 |          |          |          |               |                       |          |            | ,882**       |
| i32 |          |          |          |               |                       |          |            | ,798**       |
| i33 |          |          |          |               |                       |          |            | ,833**       |

N=444, \*p<.05, \*\*p<.01

When Table 8 is examined, as a result of the item-total correlation analysis conducted for Parten's play classification; The correlation between lone play and the items was .743 to .878; The correlation between parallel play and items was .916 to .929; The correlation between cooperative play and items was .695 to .751; The correlation between the collaborator and the items ranges from .594 to 833. As a result of the item-total correlation analysis conducted for Smilansky's game classification; The correlation between the structure-building game and the items was .813 to .869; The correlation between dramatic play and the items was .798 to .857; The correlation between the play with rules and the items varies between .788 and .874. Digital game item-total correlations range between .798 and .882. Tavşancıl (2002) suggests that item-total correlation values can be evidence for construct validity. Ural and Kılıç (2013) evaluate the correlation coefficients as 0-0.9 weak or low, 0.30-0.64 medium, 0.65-0.85 strong/high, and 0.85-1.00 very strong/very high. In this sense, it can be concluded that the factors are highly and positively related to the relevant items.

Confirmatory Factor Analysis (CFA) was conducted with the data obtained from the second study group in order to test the structure reached as a result of the exploratory factor analysis of the scale and to provide additional evidence for its construct validity. CFA results are given in Figures 1, 2 and 3 and model fit indices are given in Tables 9, 10 and 11.

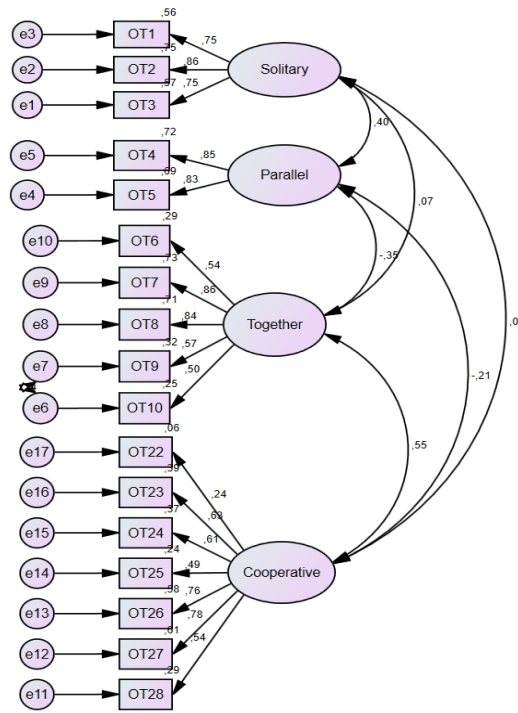

Figure 1. Parten's Play Classification DFA

As a result of CFA for Parten's play classification, the fit indices presented in Table 9 were examined to provide evidence for the validity of the model.

Table 9. Parten's Play Classification CFA Fit Indices

| Indexes    | $\chi^2$ | df  | p    | $\chi^2/df$ | RMR  | SRMR | GFI  | AGFI | IFI  | TLI  | CFI  | RMSEA |
|------------|----------|-----|------|-------------|------|------|------|------|------|------|------|-------|
| Model      | 304,81   | 112 | .000 | 2.722       | .039 | .055 | .927 | .900 | .930 | .914 | .929 | .062  |
| Evaluation |          |     |      | P           | P    | A    | A    | A    | A    | A    | A    | A     |

P= Perfect fit, A= Acceptable fit

Source: Adapted from Bayram (2013), Çelik and Yılmaz (2013) and Sümer (2000).

When Table 9 is examined, it is understood that the structure obtained from the EFA for Parten's play classification is a valid structure according to the CFA fit indices.

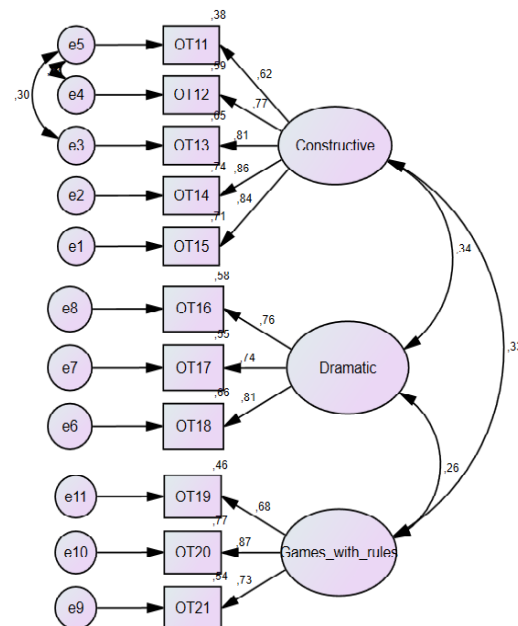

Figure 2: Smilansky's Play Classification DFA

As a result of CFA for Smilansky's play classification, the fit indices presented in Table 10 were examined in order to provide evidence for the validity of the model.



**Table 10.** Smilansky Play Classification DFA Fit Indices

| Indexes    | $\chi^2$ | df | p    | $\chi^2/df$ | RMR  | SRMR | GFI  | AGFI | IFI  | TLI  | CFI  | RMSEA |
|------------|----------|----|------|-------------|------|------|------|------|------|------|------|-------|
| Model      | 96.557   | 39 | .000 | 2.476       | .039 | .034 | .963 | .937 | .967 | .967 | .976 | .057  |
| Evaluation |          |    |      | P           | P    | P    | P    | A    | P    | P    | P    | A     |

P= Perfect fit, A= Acceptable fit

Source: Adapted from Bayram (2013), Çelik and Yılmaz (2013) and Sümer (2000).

When Table 10 is examined, it is understood that the structure obtained from the EFA for Smilansky's play classification is a valid structure according to the CFA fit indices.

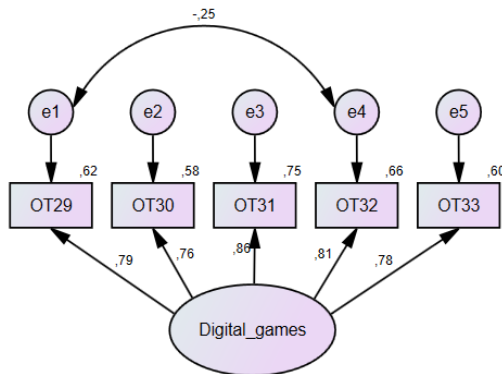

**Figure 3:** Digital Game DFA

As a result of CFA for the digital game type, the fit indices presented in Table 11 were examined in order to provide evidence for the validity of the model.

**Table 11.** Digital Game DFA Compliance Indices

| Indexes    | $\chi^2$ | df | p    | $\chi^2/df$ | RMR  | SRMR | GFI  | AGFI | IFI  | TLI  | CFI  | RMSEA |
|------------|----------|----|------|-------------|------|------|------|------|------|------|------|-------|
| Model      | 10.662   | 4  | .031 | 2.666       | .019 | .014 | .991 | .967 | .995 | .987 | .995 | .061  |
| Evaluation |          |    |      | M           | M    | M    | M    | M    | M    | M    | M    | KE    |

P= Perfect fit, A= Acceptable fit

Source: Adapted from Bayram (2013), Çelik and Yılmaz (2013) and Sümer (2000).

When Table 11 is examined, it is understood that the structure obtained from the EFA for the digital game is a valid structure according to the CFA fit indices.

In order to provide evidence for the criterion validity of the play preferences scale, the PENN Play Peer Interaction Scale was used on a study group consisting of 60 parents. The correlation analysis findings between play types and play interaction are presented in Table 12.

**Table 12.** Relationship Between Play Preferences Scale and PENN Play Peer Interaction Scale

| Plays                         | PENN Interactive Peer Play Scale |
|-------------------------------|----------------------------------|
| 1- Solitary play              | r ,197                           |
| 2- Parallel play              | r -,030                          |
| 3- Together play              | r ,677**                         |
| 4- Building-construction play | r ,194                           |
| 5- Dramatic play              | r ,068                           |
| 6- Play with rules            | r ,480**                         |
| 7- Cooperative play           | r ,570**                         |
| 8-Digital game                | r -,026                          |

N=60; \*p<.05, \*\*p<.01

According to Table 12, it is seen that there is no significant relationship between children's play interaction and solitary play (r=.197), parallel play (r=-.030), structure-construction play (r=.194), dramatic play (r=.068) and digital game (r= -.026) and play interaction (p>.05). However, it was determined that there was a significant relationship between cooperative play (r=.677), play with rules (r=.480) and cooperative play (r=.570) and play interaction (p<.05). Since interaction between children is at the forefront in social plays, it is an expected result that there will be a relationship between cooperative play, play with rules, cooperative play and play interaction, and these findings can be presented as evidence for the criterion validity of the scale.

According to the content, structure and criterion validity studies and analyses, it can be concluded that the scale is a valid scale.

### 3.2. Reliability Findings

To provide evidence for the reliability of the Play Preferences Scale, the Cronbah Alpha internal consistency coefficient was calculated and these values are presented in Table 13.

**Table 13.** Cronbach Alpha Reliability Coefficient

| Play types                      | Cronbach-Alpha Internal Consistency Coefficients After |      | Number of items |
|---------------------------------|--|------|-----------------|
|                                 | EFA  | CFA  |                 |
| Parten's play classification    | Solitary   | .762 | 3               |
|                                 | Parallel   | .823 | 2               |
|                                 | Together   | .757 | 5               |
|                                 | Collaborative  | .865 | 7               |
|                                 | Total  | .799 | 17              |
| Smilansky's play classification | Building-construction                                  | .900 | 5               |
|                                 | Dramatic   | .777 | 3               |
|                                 | Play with rules  | .778 | 3               |
|                                 | Total  | .817 | 11              |
| Digital play                    | .890   | .893 | 5               |

When Table 13 is examined, it is seen that the reliability coefficients of the scale after EFA vary between 0.757 and .900. According to Özdamar (2016), he finds the reliability coefficient between  $0.75 \leq \alpha < 0.85$  to be "highly" reliable. In this sense, it was concluded that the scale is reliable.

It is recommended to perform an independent group t test to distinguish between lower and upper groups and to make comparisons between groups (Altunışık et al., 2004). To provide evidence of the distinctiveness of the scale factors, a 27% lower-upper group comparison was made. To compare the groups, 27% of sample size was calculated. 164 participants for the 27% subgroup and 164 participants for the 27% subgroup were determined and independent samples t-test was performed. Analysis findings are shown in Table 14.

**Table 14.** 27% Lower-Upper Groups Independent Groups t-Test Results

| Play types                 | Groups | N   | MEan   | ss     | t       | df  | p    |
|----------------------------|--------|-----|--------|--------|---------|-----|------|
| Solitary play              | Lower  | 164 | 1,2909 | ,45664 | -33,905 | 326 | ,000 |
|                            | Upper  | 164 | 2,9348 | ,42079 |         |     |      |
| Parallel play              | Lower  | 164 | ,0000  | ,00000 | -31,408 | 326 | ,000 |
|                            | Upper  | 164 | 1,4098 | ,57483 |         |     |      |
| Together play              | Lower  | 164 | 2,4275 | ,41367 | -30,821 | 326 | ,000 |
|                            | Upper  | 164 | 3,6115 | ,26631 |         |     |      |
| Cooperative play           | Lower  | 164 | 2,4895 | ,40719 | -31,996 | 326 | ,000 |
|                            | Upper  | 164 | 3,7002 | ,26272 |         |     |      |
| Building-construction play | Lower  | 164 | 2,0254 | ,52409 | -32,187 | 326 | ,000 |
|                            | Upper  | 164 | 3,6144 | ,35361 |         |     |      |
| Dramatic play              | Lower  | 164 | 1,2482 | ,57691 | -34,997 | 326 | ,000 |
|                            | Upper  | 164 | 3,1750 | ,40530 |         |     |      |
| Play with rules            | Lower  | 164 | 1,5161 | ,50676 | -30,296 | 326 | ,000 |
|                            | Upper  | 164 | 3,0935 | ,43332 |         |     |      |
| Digital game               | Lower  | 164 | ,8459  | ,48282 | -34,528 | 326 | ,000 |
|                            | Upper  | 164 | 2,7924 | ,53677 |         |     |      |

When Table 14 is examined, it is revealed that there is a difference between the 27% lower and 27% upper groups ( $p < .05$ ). The score scores of the upper 27% group are significantly higher than the scores of the lower 27% group. From this finding, it is understood that all factors significantly differentiate the lower and upper groups from each other ( $p < .01$ ). In other words, it can be concluded that the reliability of the factors in the scale is high and the participants who scored the scale were able to distinguish between the types of plays to be measured.

Test-retest was conducted to provide additional evidence for the reliability of the play preferences scale. The scale was applied to 60 parents twice, with an interval of 3 weeks, and correlation analysis was performed to determine the relationship between the two applications. Analysis findings are shown in Table 15

**Table 15.** Play Preferences Scale Test-Retest Correlation Values

|           |                               | Pre-test |        |       |        |        |        |        |        |
|-----------|-------------------------------|----------|--------|-------|--------|--------|--------|--------|--------|
|           |                               | 1        | 2      | 3     | 4      | 5      | 6      | 7      | 8      |
| Post-test | 1- Solitary play              | r        | ,603** |       |        |        |        |        |        |
|           | 2- Parallel play              | r        |        | ,310* |        |        |        |        |        |
|           | 3- Together play              | r        |        |       | ,668** |        |        |        |        |
|           | 4- Building-construction play | r        |        |       |        | ,663** |        |        |        |
|           | 5- Dramatic play              | r        |        |       |        |        | ,696** |        |        |
|           | 6- Play with rules            | r        |        |       |        |        |        | ,655** |        |
|           | 7- Cooperative play           | r        |        |       |        |        |        |        | ,574** |
|           | 8-Digital game                | r        |        |       |        |        |        |        |        |

N=60; \*p<0.05, \*\*p<0.01

When Table 15 is examined, it can be seen that the test-retest values of the play preferences scale are significant. It was determined that the test-retest correlation values of other play types, except parallel play (r = .310), ranged between r = .574 and r = .857. According to these values, it can be said that the scale gives consistent results. As a result of the reliability analysis, it is understood that the scale is a reliable scale.

**4. Discussion and Conclusion**

The aim of the study was to develop a Likert-type scale that can measure validly and reliably the play preferences of preschool children. In the Likert-type scale, response options are offered to the item expressed as a sentence, indicating the level of agreement or approval for that item (Devellis, 2014). The scale is a 5-point Likert type scale; It is evaluated as “Never” (0), “Rarely” (1), “Occasionally” (2), “Mostly” (3), “Always” (4). The content validity of the scale was tried to be ensured by reviewing the literature and obtaining expert opinions. Content validity requires collaboration with field experts (Tavşancıl, 2002).

Factor analysis was performed for the construct validity of the scale. KMO and Bartlett's test values were examined before factor analysis. KMO values were 0.898, 0.842 and 0.859, respectively, and Bartlett's test was found to be significant (p<.001). According to Tavşancıl (2002), a KMO value of 0.80 and above indicates that the data is suitable for factor analysis. As a result of the factor analysis, a structure with 8 factors and 33 items emerged. After item extraction for Parten's play classification, 4 factors with eigenvalues above 1 emerged. The total variance explained by 4 factors is 61.625%. In the first analysis of Smilansky's play classification, there were 3 factors with eigenvalues above 1. The total variance explained by 3 factors is 70.827%. The factor of the digital game is one-dimensional, its eigenvalue is 3.493 and the variance it explains is 69.853%. According to Özdamar (2016), during the scale development process, he suggests that the proportion of variance explained by a scale should be 40% or more. In this respect, it was decided that the variance ratio explained by the factors was at the recommended rate. As a result of the Confirmatory Factor Analysis (CFA), which was conducted to provide additional evidence for the construct validity of the scale, the fit indices confirmed the structure obtained from EFA. For criterion validity, the correlation between the PENN game interaction scale and the Play Preferences Scale (PSS) was examined and a significant relationship was found between cooperative play, play with rules and cooperative play. According to the content, structure and criterion validity studies and analyses, it can be concluded that the scale is a valid scale.

Cronbach Alpha (CA) reliability value was calculated to calculate the consistency between all items of the scale after EFA and CFA. It is seen that the reliability coefficients of the scale after EFA and CFA vary between 0.757 and 0.900. According to Özdamar (2016), finds the reliability coefficient between 0.75≤a<0.85 to be "highly" reliable. In this sense, it was concluded that the scale is reliable. To provide evidence of the discriminative properties of the items, it is recommended to conduct a 27% lower-upper groups t test (Altunışık et al., 2004). It was revealed that there was a difference between the lower and upper groups of 27% (p <.05). The score scores of the upper 27% group are significantly higher than the scores of the lower 27% group. In other words, it was concluded that the reliability of the factors in the scale was high and that the

participants who scored the scale were able to distinguish between the types of plays to be measured. Test-retest was conducted to provide additional evidence for the reliability of the play type preferences scale. Test-retest is the application of the same measurement tool to the same group for a certain period of time and determining the relationship between the two applications (Tavşancıl, 2002). The scale was applied to 60 parents twice with an interval of 3 weeks, and as a result of the correlation analysis performed to determine the relationship between the two applications, a significant relationship was determined between  $r = .574$  and  $r = .857$  ( $p < .05$ ). When all studies were evaluated, it was concluded that the play type preferences scale is a measurement tool that can validly and reliably measure the game preferences of children receiving preschool education. The sub-dimensions of the scale and the distribution of play types according to the items are given below.

Solitary Play: 1-2-3

Parallel Play: 4-5

Together Play: 6-7-8-9-10

Structure – construction Play: 11-12-13-14-15

Dramatic Play: 16-17-18

Game with Rules: 19-20-21

Cooperative Play: 22-23-24-25-26-27-28

Digital Game: 29-30-31-32-33

If the Play Preferences Scale is used in future studies in the field of preschool education, calculating and reporting CFA fit values and Cronbach Alpha reliability values will strengthen the validity and reliability of the scale. Additionally, the impact of children's play preferences on their developmental areas can be examined.

## 5. References

- Altunışık, R., Coşkun, R., Bayraktaroğlu, S., & Yıldırım, E. (2004). *Sosyal bilimlerde araştırma yöntemleri* (Research methods in social sciences). Sakarya Kitabevi.
- Atay, M. (2017). *Erken çocukluk döneminde gelişim 2* (Development in early childhood 2). Kök.
- Bacanlı, H. (2018). *Eğitim psikolojisi* (Education psychology). Pegem.
- Bardak, M. & Topaç, M. (2021). *Oyun ve oyun materyalleri* (Play and play materials). Efe.
- Başaran, İ. E. (2011) *Çocuk yetiştirmede sorunlar ve çözümleri; ana-babanın eğitimi el kitabı* (Problems and solutions in raising children; parent education handbook). Remzi.
- Bayındır, D. & Mısırlı, Z. A. (2020). Dijital oyunlar (Digital games). In A. Önder, and H. Arslan Çiftçi (Eds), *Erken çocuklukta oyun ve oyun yoluyla öğrenme* (In play and learning through play in early childhood) (pp. 261-282). Nobel.
- Bayındır, D. ve Uyanık Balat, G. (2018). Erken çocukluk eğitiminde sınıfta davranış yönetimi (Classroom behavior management in early childhood education). In G. Uyanık Balat and H. Bilgin (Eds.) *Erken çocukluk eğitiminde sınıf yönetimi* (Classroom management in early childhood education)(pp. 63-86). Anı.
- Bayram, N. (2013). *Yapısal eşitlik modellemesine giriş* (Introduction to structural equation modeling). Ezgi.
- Berk, L. E. (2020). *Bebekler ve çocuklar doğum öncesinden orta çocukluğa* (Infants and children prenatal through middle childhood) (N. Işıkoğlu Erdoğan, Trans. Ed.). Nobel.
- Bredenkamp, S. (2015). *Erken çocukluk eğitiminde etkili uygulamalar* ( Effective Practices in Early Childhood Education) (H. Z. İnan & T. İnan, Trans. Eds.). Nobel.
- Brink, P. J. & Wood, M. J. (1998). *Advanced design in nursing research*. Sage.

- Budak, K. S. (2020). *Okul öncesi dönem çocukları için dijital oyun bağımlılık eğilimi ölçeğinin ve dijital oyun ebeveyn rehberlik stratejileri ölçeğinin geliştirilmesi, problem davranışlarla ilişkisinin incelenmesi* (Development of digital game addiction tendency scale and digital game parent guidance strategies scale for preschool children and examination of their relationship with problem behaviors) [Master's thesis]. Pamukkale University, Denizli.
- Büyüköztürk, Ş., Kılıç Çakmak, E., Akgün, Ö. E., Karadeniz, Ş., & Demirel, F. (2012). *Bilimsel araştırma yöntemleri* (Scientific research methods). Pegem.
- Camgöz, A. (2010). *Ankara örnekleminde penn etkileşimli akran oyunu ölçeğinin 60-72 aylık düşük sosyoekonomik düzeydeki çocukların ebeveyn ve öğretmenlerine uyarlanması* (Adaptation of the Penn Interactive Peer Play Scale to parents and teachers of 60-72 month old children with low socioeconomic status in Ankara sample.) [Master's thesis]. Gazi University, Ankara.
- Çelik, H. E. & Yılmaz, V. (2013). *Yapısal eşitlik modellemesi* (Structural equation modeling). Anı.
- Devellis, R. F. (2014). *Ölçek geliştirme kuram ve uygulamalar* (Scale development: Theory and applications), (T. Totan, Trans.). Kaknüs.
- Dörnyei, Z. & Taguchi, T. (2009). *Questionnaires in second language research: Construction, administration, and processing*. Routledge.
- Duralp, E. & Aral, N. (2010). Altı yaşındaki çocukların sosyal becerilerine oyun temelli sosyal beceri eğitiminin etkisinin incelenmesi (Examining the effect of game-based social skills training on the social skills of six-year-old children). *H. U. Journal of Education*, 39. 160-172.
- Erkuş, A. (2014). *Psikolojide ölçme ve ölçek geliştirme I: Temel kavramlar ve işlemler* (Measurement and scale development in psychology I: Basic concepts and procedures.). Pegem.
- Evertson, C. M. & Emmer, E. (2013). *İlkokul öğretmenleri için sınıf yönetimi* (Classroom management for elementary teachers) (A. Aypay, Trans. Ed.). Nobel.
- Finger, J. & Bamford, B. (2010). *Sınıf yönetimi stratejileri öğretmen kılavuzu* (The classroom teachers book of management essentials) (T. Karaköse, Trans. Ed.). Nobel.
- Gencer, R. (2022). *Okul öncesi eğitime devam eden 60-72 aylık çocukların prososyal ve oyun davranışları arasındaki ilişkinin incelenmesi* (Examining the relationship between prosocial and play behaviors of 60-72 month old children attending pre-school education) [Master's thesis]. Kütahya Dumlupınar University.
- George, D. & Mallery, P. (2019). *IBM SPSS Statistics 26 step by step: A simple guide and reference*. Routledge.
- Gürpınar, H. A. (2006). *Okulöncesi öğrenime devam eden çocukların tercih ettikleri ilgi köşeleri ve tercih etme nedenleri* (Interest corners preferred by children attending preschool and their reasons for choosing them) [Master's thesis]. Anadolu University, Eskişehir.
- Huizinga, J. (2021). *Homo ludens*. Ayrıntı.
- Kaya, G. İ. (2018). Oyun, gelişim ve tarihsel olarak oyunun eğitimdeki yeri (Play, development and historically the place of play in education). *Ulusal Eğitim Akademisi Dergisi*, 2(1), 66-78.
- Lawshe, C. H. (1975). A quantitative approach to content validity. *Personnel Psychology*, 28(4), 563-575.
- Metin Aslan, Ö. (2013). *Anaokuluna devam eden çocukların oyun davranışları ve oyunlarında ortaya çıkan zorbalık davranışlarının incelenmesi* (Examining the play behaviors of children attending kindergarten and the bullying behaviors that occur in their play) [Doctoral dissertation]. Hacettepe University, Ankara.
- Penn Early Childhood and Family Research Center (2023). *The Penn interactive peer play scale (PIPPS)*. <https://child.gse.upenn.edu/products/pipps>
- Otrar, M. & Arğın, F. S. (2015). Öğrencilerin sosyal medyaya ilişkin tutumlarını belirlemeye yönelik bir ölçek geliştirme çalışması (A scale development study to determine students' attitudes towards social media). *Eğitim ve Öğretim Araştırmaları Dergisi*, 4(1), 391-403.

- Özdamar, K. (2016). *Eğitim, sağlık ve davranış bilimlerinde ölçek ve test geliştirme yapısal eşitlik modellemesi* (Structural equation modeling of scale and test development in education, health and behavioral sciences). Nisan.
- Santrock, J. W. (2017). *Yaşam boyu gelişim* (Life-span development) (G. Yüksel, Trans. Ed.). Nobel.
- Sevinç, M. (2009). *Erken çocukluk gelişimi ve eğitiminde oyun* (Play in early childhood development and education). Morpa.
- Slavin, R. E. (2019). *Eğitim psikolojisi kuram ve uygulama* (Educational psychology theory and practice) (G. Yüksel, Trans. Ed.). Nobel.
- Sümer, N. (2000). Yapısal eşitlik modelleri: Temel kavramlar ve örnek uygulamalar (Structural equation models: Basic concepts and example applications). *Türk Psikoloji Yazıları*, 3(6), 49-74.
- Şen, M. (2014). Erken çocukluk eğitiminde oyun ve önemi (Play and its importance in early childhood education). In İ. H. Diken. (Ed.), *Erken çocukluk eğitimi* (Erken çocukluk eğitimi içinde) (pp. 404- 431). Pegem.
- Tavşancıl, E. (2002). *Tutumların ölçülmesi ve SPSS ile veri analizi* (Measurement of attitudes and data analysis with SPSS). Nobel.
- Trawick-Smith, J. (2018). *Erken çocukluk döneminde gelişim* (Early childhood development a multicultural perspective) (B. Akman, Trans. Ed.). Nobel.
- Ural, A. & Kılıç, İ. (2013). *Bilimsel araştırma süreci ve SPSS ile veri analizi* (Scientific research process and data analysis with SPSS). Detay.
- Ünsal, Ö. F. (2020). Oyun türleri ve oyun alanları (Play types and playgrounds). In A. Önder and H. Arslan Çiftçi (Eds.), *Erken çocuklukta oyun ve oyun yoluyla öğrenme* (Play and learning through play in early childhood) (pp. 73-94). Nobel.
- Yavuzer, H. (1999). *Çocuk psikolojisi* (Child psychology). Remzi.
- Yörükoğlu, A. (1978). *Çocuk ruh sağlığı* (Child mental health). İş Bankası Kültür Yayınları.