



The Romanian Version of the Revised Youth Purpose Survey (RYPS): Psychometric Evaluation for Emerging Adults

Beatrice Adriana Balgiu

University Politehnica of Bucharest, România
Department of Career and Educational Training

ARTICLE INFO

Article History:

Received 16.01.2019

Received in revised form

20.04.2019

Accepted 30.04.2019

Available online

26.05.2019

ABSTRACT

The present article looks into the psychometric properties of the Revised Youth Purpose Survey (RYPS) in the case of a group of Romanian students emerging adults (N = 500). RYPS is a ten-item scale made of two sub-scales which measure Purpose Exploration (4 items) and Purpose Commitment (6 items). Confirmatory factorial analysis indicated an adequate fit of a two-factor model (GFI = .96; AGFI = .94; RMSEA = .057). This structure was confirmed and it was invariant for gender. Cronbach's alpha coefficients show good internal consistency: .87 (Purpose Exploration subscale) and .77 (Purpose Commitment subscale). The correlations of both scales of RYPS with validation measures of psychological and subjective well-being and of identity orientations were positive, indicating good convergent validity. The study validated the conceptual vision of the authors of the instruments in a previously unstudied cultural context.

© 2019IJPES. All rights reserved

Keywords:

validation; purpose; RYPS; purpose exploration; purpose commitment

1. Introduction

Setting and achieving one's purposes in life are essential for the individual's life during the transition period to maturity. In the domain of psychology, the topic of the purpose as a motivational force was much researched on (Frankl, 1959; Hayes, Strosahl, & Wilson, 1999; Yalom, 1980), given its importance for adolescence (Bronk & Finch, 2010; Bronk, Finch, & Talib, 2010; Yeager & Bundick, 2009; Yeager, Bundick, & Johnson, 2012) and emerging adulthood (Bundick, 2011; Damon, 2008; Massey, Gebhardt, & Garnefski, 2008; Sumner, Burrow, & Hill, 2015). The construct of "purpose" typically entails: 1) aim, as a quality indicating an intention related to a long-term goal and 2) engagement, as an internal motivation to be active in the pursuit of the personally meaningful aim (Bronk et al., 2010; Damon, Menon, & Bronk, 2003; Moran, 2009).

According to Damon (2008), a purpose in life is a stable and generalized intention to achieve something that is simultaneously significant for oneself and leads to productive engagement with the world beyond oneself. McKnight and Kashdan (2009) put forth an additional definition which describes the purpose as a central and self-organized aim in life that organizes and stimulates goals, manages behaviours, and provides a sense of meaning. Establishing a purpose in life is considered a central aspect of one's existence since it strongly influences one's identity; it is also considered self-organising because it has a paradigm that informs an individual's daily behaviour. As such, the purpose influences the behaviour and it has a great impact on one's conception of and direction in life.

The relevance of the studies on one's purpose in life has been demonstrated in most papers by means of associating it with well-being and identity. Thus, certain pieces of research considered that the purpose is an

¹ Corresponding author's address: University Politehnica of Bucharest, Department of Career and Educational Training for Social and Human Sciences, Splaiul Independenței, 313, București, sector 6, România

e-mail: beatrice.balgiu@upb.ro

<http://dx.doi.org/10.17220/ijpes.2019.02.002>

important aspect of eudaimonia (Ryan & Deci, 2001), or psychological well-being (Ryff, 1989; Ryff & Singer, 1998), and consequently, a reflection of one's psychological flourishing and of one's life led in accordance with one's values. Research has shown that the fulfilment of one's purpose is associated with a higher degree of life satisfaction (Bronk, Hill, Lapsley, Talib & Finch, 2009) and with daily happiness, emotional stability (Kiang & Fuligni, 2010). Both the exploration and the fulfilment of the purpose are associated with greater life satisfaction in the case of young people and emerging adults (Bronk et al. 2009). Sumner et al. (2015) found a significant relationship between the exploration of the purpose and the negative affect, as well as between the fulfilment of the purpose and the positive affect. The study carried out on 850 emerging adults shows that the exploration of the purpose is predictive of greater negative affect and a lower degree of life satisfaction, while the fulfilment of the purpose is predictive of life satisfaction and positive affect.

As for the relationship between purpose and identity, theoretical and empirical works agreed on the strong association of the two notions (Bronk, 2011; Hill & Burow, 2012; Sumner et al., 2015). For example, research on teenagers has shown that the development of identity consolidates the fulfilment of a purpose in life and that purpose helped those teenagers understand what they did and how they fit into a larger context (Bronk, 2011). Burrow and Hill (2011) examined the mediating role that purpose has in the relationship "identity – well-being" in the case of teenagers and emerging adults. The results showed that purpose commitment fully mediates the relationship "identity – changes" in daily positive and negative affectivity. In general, findings suggest that establishing a purpose in life may be an important mechanism through which a stable identity contributes to well-being.

The considerable number of pieces of research on purpose in the Western culture led to a relatively large number of purpose measurements. For a broader perspective on the phenomenon and of the instruments used see Bronk's study (2014) focused on the analysis of the purpose in life – *Purpose in Life* (especially the second chapter, *Measuring Purpose*). Most of these instruments are developed around Victor Frankl's conception (1959), according to whom mental disorders are caused by existential factors such as the lack of purpose. This is the foundation of the first survey of purpose in life: Frankl Questionnaire (13 items). Frankl set the model for other instruments developed later: the Purpose in Life Test (Crumbaugh & Maholick, 1964), the Existence Subscale of Purpose in Life Test - EPIL (Law, 2012), the Life Purpose Questionnaire - LPQ (Hablas & Hutzell, 1982; Hutzell, 1989), Seeking of Noetic Goals Test (SONG, Crumbaugh, 1977), and Life Attitude Profile-Revised - LAP-R (Reker, 1992).

One of the most recent instruments founded on Frankl's theory is the *Revised Youth Purpose Survey* (RYPS – Bundick, Andrews, Jones, Mariano, Bronk, & Damon, 2006), whose objective is the assessment of both the identification of the purpose and of the search for a purpose in the case of the teenagers and emerging adults. The survey was first called the Youth Purpose Scale, it had 20 items (Bundick et al, 2006), and it was constructed by borrowing items from related measures of purpose (Ryff Scales of Psychological Well-being – Ryff & Keyes, 1995) and meaning in life (Meaning in Life Questionnaire – Steger, Frazier, Oishi & Kaler, 2006). This survey was structured around two subscales: the Identified Purpose Subscale (15 items) and the Searching for Purpose Subscale (5 items). Bronk et al. (2009) report a Cronbach's alpha of .94 for each subscale.

As provided by Stanford Center on Adolescence Youth Purpose Project, RYPS is made of two subscales: the Purpose Exploration Subscale – PE (4 items; example: *I am always looking to find my life's purpose*; $\alpha = .79$ and for 6th graders, $\alpha = .75^2$); and the Purpose Commitment Subscale - PC (6 items; item example: *I have a purpose in my life that reflects who I am*; $\alpha = .85$ and for the 6th graders, $\alpha = .80$). All the items on the scale are measured from 1 (*strongly disagree*) to 7 (*strongly agree*). Sections 2 (The categories of identified purpose scale), 3 (Life goals scale), and 4 (Activity involvement scale), established by Stanford Center on Adolescence Youth Purpose Project are used only if the respondents showed a strong sense of purpose for the scale Purpose Commitment, and if one wishes to continue to identify purposes, as they have the role to provide more information on how respondents find their purpose in life.

To the best of our knowledge the actual studies of RYPS validation are very few although the instrument was used in many studies in association with moral identity (Hardy, Walker, Olsen, Woodbury, &

² indices provided by Stanford Center on Adolescence Youth Purpose Project

Hickman, 2014), hope and life satisfaction (Bronk et al., 2009), well-being (Hill, Burrow, Brandenberger, Lapsley, & Quaranto 2010), identity and subjective well-being (Sumner et al., 2015), self-esteem, and the parents-children relationship (Blattner, Liang, Lund, & Spencer, 2013), voluntary service activity engagement (Han, Kim, Jeong, & Cohen, 2017), civic engagement, and prosocial tendencies (Douglas, 2015).

Given the absence of resources and instruments necessary for the evaluation of the purpose in an educational context, we proposed the examination of the psychometric properties of the Revised Youth Purpose Survey – RYPS on a sample of Romanian subjects, by using the short form of RYPS with 10 items. The method used for translation of the RYPS was forward translation, from English in Romanian and next in the English language. Both versions did not differ noticeably.

2. Method

2.1. Participants and procedure: The psychometric data from this paper comes from processing the answers of a number of 500 undergraduates (257 male and 243 females) ($\bar{X}_{age} = 19,02$; S.D. = 1,38) from one large technical public university. The students were randomly selected from the years of study I and II. Data collection for the study took place in academic years 2016/2017 and 2017/2018. Participants provided informed consent and completed the measures voluntarily and anonymously. The measures were administered in groups and each administration was completed in about 20 minutes. The study subjects were not rewarded for participating in the study.

2.2. Data Collection Instruments

The data of the study were collected through Revised Youth Purpose Survey – RYPS, Scale of Positive and Negative Experience – SPANE, Satisfaction with Life Scale – SWLS, Short psychological well-being scale – SPWB and Aspects of Identity Questionnaire – AIQ-IV.

2.2.1. Scale of Positive and Negative Experience – SPANE (Diener et al., 2009) assess a broad range of pleasant and unpleasant feelings by asking people to report their feelings in terms of their duration after recalling their activities and experiences during the previous 4 weeks. The SPANE consists of 12 items: six items assess positive feelings (SPANE-P), and the other six assess negative feelings (SPANE-N) on a scale from 1 – *very rarely or never* to 5 – *very often or always*. Finally, affect balance is also calculated (SPANE-B): the negative feelings score is subtracted from the positive feelings score. The studies have reported optimal validity of the scale in the case of 21 322 full-time workers (Li, Bai & Wang, 2013). In the present study, Cronbach's alpha indices were .85 (SPANE-P) and .83 (SPANE-N).

2.2.2. Satisfaction with Life Scale – SWLS (Diener, Emmons, Larsen, & Griffin, 1985) takes into account the cognitive assessment of life satisfaction. The SWLS is a short 5-item instrument designed to measure global cognitive judgments of satisfaction with one's life. The SWLS is a 7-point Likert style response scale. Sample item: *In most ways, my life is close to my ideal*. Test-retest reliabilities have ranged from .83 (2 weeks) to .54 (4 years), and coefficients alpha have ranged from .79 to .89 (Pavot & Diener 1993; Pavot, Diener, Colvin, & Sandvik, 1991). Regarding Cronbach's alpha, similar findings were observed on the Romanian students, $\alpha = .82$, (Cazan, 2014). The scale also showed high internal consistency in the present study ($\alpha = .80$). The validations of the scale were made, in most cases, in correlation with the instruments that measure hope (Bayley, & Snyder, 2007; Galanakis, Lakioti, Pezirkianidis, Karakasidou, & Stalikas, 2017), meaning in life (Steger, Frazier, Oishi, & Kaler, 2006], happiness, (Caycho-Rodríguez, et al. 2018; Galanakis et al., 2017), perceived health and social support (López-Ortega, Torres-Castro, & Rosas-Carrasco, 2016) etc.

2.2.3. Short psychological well-being scale – SPWB (Ryff & Singer, 1998) is a self-report inventory with 18 items grouped into six subscales: Autonomy (“I believe in my own opinions even if they differ from others”); Environmental control (“I manage my day-to-day responsibilities well”); Personal growth (“For me, life was a continuous learning, growth, and development process”); Positive relationship with the other people (“People describe me as a person who likes spending time with others”); Life purpose (“Some people wander aimlessly in their life, but I am not one of them”) and Self-acceptance (“In general, I like most parts of my personality”). Every scale has 3 items (8 of them reverse) assessed on a scale from 1 – *strongly disagree* to 6 – *strongly agree*; $\alpha = .55$ to $.70$ on adolescents). The scale has been validated in many cultural contexts

(Lin, 2015; Luștrea, Al Ghazi & Predescu, 2018; Villarosa & Ganotice, 2018). In the present investigation, Cronbach's alpha values ranged from .65 to .72.

2.2.4. Aspects-of-Identity Questionnaire – AIQ-IV (Cheek, Smith, & Tropp, 2002) measure identity orientations (45 items) on a scale from 1 – *Not important to my sense of who I am* to 5 – *Extremely important to my sense of who I am*. The identity orientations are divided into *Personal identity orientation* - our private beliefs about our psychological traits (10 items – e.g. “My personal values and moral standards”); *Relational identity orientation* - how we see ourselves in the context of our intimate relationships (10 items – e.g. “My relationships with the people I feel close to”); *Social identity orientation* - how we see ourselves in more general interpersonal contexts (7 items – e.g. “My reputation, what others think of me”); *Collective identity orientation* - how we represent our various reference group identities (8 items – e.g. “My race or ethnic background”). 10 special items do not score. Personal and Relational identity are rather characterized as independent/individualistic and Social and Collective identity are at the opposite pole, characterized as interdependent/collectivistic. The Cronbach's alphas reported by authors are $\alpha = .72$ to $.92$ (Cheek, & Briggs, 2013; Cheek, Smith & Tropp, 2002). In the present study, Cronbach's alpha values ranged from .69 to .82. AIQ-IV was validated by exploratory factor analysis, confirmatory factor analysis and test-retest (Yin, & Etilé, 2019).

2.3 Analysis strategies were conducted using SPSS 22 and Amos 20 to examine items and subscales properties, such as the confirmatory factorial analysis and invariance for gender, descriptive statistics, internal consistency, bivariate correlations with other validated measures.

3. Results and discussion

3.1. Factorial structure

Confirmatory factor analysis was used to test the hypothesis that the scale measured two constructs. Assessment of multivariate normality distribution was performed using Mardia's Multivariate Normality Test. Because the critical ratio of the Mardia's coefficient of multivariate kurtosis was greater than 1.96 ($CR = 19.41$), the sample can be considered multivariate non-normal. One means of managing non-normality is the distance criteria proposed by Mahalanobis. In order to normalize the distribution, one needs to identify and to eliminate the cases of outliers. But this can lead to the loss of the power of the model. Under these circumstances, we considered that one robust way of managing non-normality is bootstrap resampling.

Therefore, the method of Maximum Likelihood (ML) with bootstrapping was employed. To assess model fit, different indexes of fit were examined in confirmatory factor analysis (CFA): *chi-square value*, *df*, *GFI* (goodness-of-fit index), *AGFI* (adjusted goodness-of-fit index), *PGFI* (parsimony of goodness-of-fit index), *CFI* (comparative fit index), *RMSEA* (root mean squared error of approximation), *SRMR* (standardised root mean square residual).

Two models were tested, one with a single factor and the second with two factors. The latter turned out to be appropriate. For each and every factor we co-varied the items with the highest value of modification indices. For Purpose exploration scale we co-varied item e1 (“I am looking for something that makes my life meaningful”) and item 3 (“I am seeking a purpose of a mission for my life”), and for Purpose commitment scale we co-varied item e5 (“I have discovered a satisfying life purpose”) and item e6 (“I understand my life's meaning”), item e7 (“I participate in one or more organizations that serve my purpose in life”) and e9 (“I have a purpose in my life that reflects who I am”), and in the end item e7 (“I participate in one or more organizations that serve my purpose in life”) and e10 (“I have a life purpose that says a lot about the kind of person I am”). After each constraint of the co-variants, the values of the indicators mentioned above improved.

Table 1 shows the two-factor structure seems to be the best fitting model $\chi^2 = 78,371$; $df = 30$; $\chi^2/df = 2,62$; $GFI = .969$; $AGFI = .942$; $PGFI = .529$; $CFI = .895$; $RMSEA = .057$ (90% Confidence Interval (CI)); $SRMR = .061$; $p = .001$ than one factor model: $\chi^2 = 85,167$; $df = 22$; $\chi^2/df = 3,87$; $GFI = .962$; $AGFI = .905$; $PGFI = .385$; $CFI = .847$; $RMSEA = .080$ (90% Confidence Interval (CI)); $SRMR = .079$; $p = .001$. All the standardized factor loadings of

the RYPS were above .70 for Purpose exploration scale and over .45 for Purpose commitment scale (see figure 1).

Table 1. Confirmatory factor model

Model	χ^2	df	CMIN/df	GFI	AGFI	PGFI	CFI	RMSEA (90%)	(CI SRMR)
Single factor	85,167	22	3,87	.962	.905	.385	.847	.080 (.062 - .098)	.079
Two factor	78,371	30	2,62	.969	.942	.529	.895	.057 (.047 - .080)	.061

3.2. Factorial invariance

With a view to analysing the factorial invariance, we studied the hierarchy of models with constraints for the gender-related criterion. Initially, the model was tested without constraints both for male and female subjects (model 1). Both RMSEA and CFI were adequate (table 2). A second model imposed constraints in factor loadings (model 2). The estimations of the model fit the data at an acceptable level. The third model (model 3)

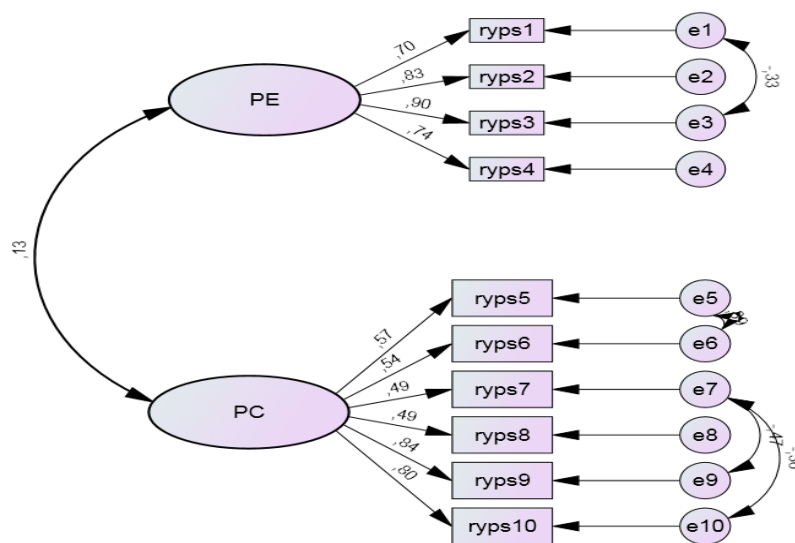

*Figure 1 Confirmatory factorial analysis of the RYPS
PE – purpose exploration, PC – purpose commitment*

tested the constraints imposed in covariances. Data provide a fit for this model. Thus, for the sample on which RYPS was tested psychometrically, the measurement model was invariant depending on the gender-related variables ($\Delta CFI = .001$ and $\Delta\chi^2$ was not significant). The differences regarding other indexes of fit are nonexistent (RMSEA) or negligible (i.e. GFI, TLI).

Table 2. Factorial invariance across gender

Model	χ^2	df	CMIN/df	CFI	RMSEA (CI 90%)	Model comparison	p
Model 1 No constraints	125,643	60	2,09	.962	.049 (.037-.062)	-	-
Model 2 Factor loading constrained	126,012	61	2,06	.963	.049 (.037-.061)	2 vs. 1 $\Delta\chi^2 = 0.36$ $\Delta df = 1$.544
Model 3 Factor loading and covariance constrained	126,012	61	2,06	.963	.049 (.037-.061)	3 vs. 1 $\Delta\chi^2 = 0.36$ $\Delta df = 1$.544

3.3. Descriptive statistics

Table 3 shows the descriptive statistics. Regarding the gender-related difference, there was only one distinction for the Purpose Exploration scale for which female subjects had higher scores than the male ones (\bar{X} male = 21,22; S. D. = 5,42; \bar{X} female = 23,16; S. D. = 4,65; $t = -4,80$; $p = .000$). Internal consistency was assessed using Cronbach's alpha. According to Hair, Black, Babin & Anderson (2014), the coefficient alpha obtained for the two scales, Purpose exploration: $\alpha = .87$ and Purpose commitment: $\alpha = .77$, show that the questionnaire is highly reliable.

For the sub-samples of males and females, respectively, the values of internal consistency were .84 and .88, respectively, for the Purpose Exploration scale and .77 and .78., respectively, for the scale Purpose Commitment. For the assemblies represented by the RYPS items which resulted after eliminating each item at a time, the values of coefficient α were: .73 – item 1; .72 – item 2; .72 – item 3; .71 – item 4; .72 – item 5; .73 – item 6; .76 – item 7; .72 – item 8; .71 – item 9; .70 – item 10.

Table 3. Descriptive statistics

	\bar{X}	S.D.	Skewness	Kurtosis
1. I am looking for something that makes my life feel meaningful	5,72	1,51	-1,19	.77
2. I am always looking to find my life's purpose	5,52	1,47	-.97	.39
3. I am seeking a purpose or mission for my life	5,45	1,47	-.89	.22
4. I am always searching for something that makes my life feel significant	5,32	1,48	-.77	-.00
5. I have discovered a satisfying life purpose	4,22	1,52	-.08	-.75
6. I understand my life's meaning	4,08	1,63	-.02	-.75
7. I participate in one or more organizations that serve my purpose in life	2,95	1,78	.65	-.56
8. I am always working toward accomplishing my most important goals in life	5,58	1,37	-.74	-.24
9. I have a purpose in my life that reflects who I am	5,07	1,63	-.68	-.35
10. I have a life purpose that says a lot about the kind of person I am	5,05	1,63	-.64	-.40
Purpose exploration score	5,51	1,25	-	-
	$\alpha = .87$			
Purpose commitment score	4,49	1,09	-	-
	$\alpha = .77$			

3.4. Convergent validity

Consistent with prior studies (Bronk et al., 2009; Sumner et al., 2015), Purpose Commitment scale correlates both with subjective well-being (life satisfaction – SWLS and the Positive Affect scale from SPANE), as well as with the total score of psychological well-being (all the scales in SPWB) and the four orientations of identity: personal, relational, social, and collective identity (AIQ-IV). The Purpose Exploration scale correlates with the negative affect (SPANE), the Personal Growth subscale (SPWB) and two of the orientations of identity - personal, and relational identity (AIQ-IV).

As the correlations with instruments mentioned show (table 4), the individuals who declare they fulfil their purpose live subjective well-being (positive affect – $r = .22$; $p < .01$; life satisfaction – $r = .47$; $p < .01$) and psychological well-being at a high level (total score PWB – $r = .47$; $p < .01$) and it seems that identity is constructed in a bipolar manner, both individually (personal identity – $r = .21$; $p < .01$; relational identity – $r = .15$; $p < .05$) and socially (social identity – $r = .21$; $p < .01$; collective identity – $r = .37$; $p < .01$). The students engaged in the exploration of the purpose live negative affectivity ($r = .15$; $p < .05$), they need personal growth, and they are rather idiocentric (personal identity – $r = .15$; $p < .05$; relational identity – ($r = .15$; $p < .05$). There is a weak, still significant correlation between Purpose Exploration and Purpose Commitment ($r = .13$; $p = 0.05$).

Table 4. RYPS bivariate correlations with validated measures

	Variables	Purpose exploration	Purpose commitment	
SPANE	Positive affect	.04	.22**	
	Negative affect	.15*	-.12	
SWLS	Life satisfaction	.01	.47**	
	Autonomy	.00	.28**	
SPWB	Control	.19	.25**	
	Personal growth	.20**	.22**	
	Relationships	.03	.26**	
	Life purpose	-.04	.15*	
	Self-acceptance	.02	.43**	
	Total SPWB	.07	.47**	
	AIQ-IV	Personal identity	.32**	.21**
		Relational identity	.19**	.15*
Social identity		.06	.21**	
Collective identity		.13	.37**	

** $p < .01$; * $p < .05$

4. Conclusions

The research aimed at investigating the psychometric properties of RYPS in the case of a group of students who need to develop resources and instruments available to the psychology of purpose in the educational context. On the whole, the evidence indicates that RYPS has acceptable psychometric properties. RYPS has two distinct sub-scales in its composition: Purpose Exploration Subscale that shows the extent to which the individual is exploring his purpose and the Purpose commitment showing the extent to which the individual has achieved his purpose. CFA show that the two-factor model is appropriate and it has acceptable coefficients. This study confirmed the original structure of the instrument. The obtained standardized factor loadings are over .70 for the Purpose Exploration subscale and over .45 for the Purpose Commitment subscale.

Psychometric characteristics were analyzed by means of consistency values, of the factorial structure, and by testing the relationship with other variables. Furthermore, the internal consistency was good, namely .87 and .77 (total sample), .78 and .88 (female subjects) and .77 and .84 (male subjects), which shows that RYPS is a valid instrument for the measurement of purpose in the case of emerging adults. In the present study, we provide evidence in support of the convergent validity by investigating the relationship between RYPS and

other measures such as those for the subjective and the psychological well-being, and identity orientations. In these conditions, RYPS show good convergence validity.

Like any other study, the present one has its limitations. One of them is the sample of students obtained from only one university. In the present study, the model obtained for RYPS is adequate, on condition that we allow a correlation between the errors of the variance of some items (i.e. "I participate in one or more organizations that serve my purpose in life"). This suggests that there could be factors that could explain the difference of variance errors between the items. Taken together, results suggest that the RYPS represents a promising measure of the adolescents' and emerging adults' purpose in life. Our findings provide evidence of the applicability of the RYPS in the Romanian context especially in the case of the young population. That is why it is important to continue evaluating of the instrument on other age groups, especially adolescents. Since RYPS contains items of meaning in life, borrowed from the Meaning in Life Questionnaire – ML-Q (Steger et al., 2006), it is important to investigate when individuals develop a sense of purpose in life and which environments support this development. Clearly, it is important to explore the properties of RYPS in association with other aspects of wellness.

Considering the results of this study, we highlight the importance of other validation forms, of external validity, in particular, as well as the application of the measure to the general population as compared to its application to the specific population.

Acknowledgment

"This research used, with permission, the *Revised youth purpose survey* (Bundick, Andrews, Jones, Mariano, Bronk, & Damon, 2006) from the Stanford Center on Adolescence Youth Purpose Project, funded in part by the John Templeton Foundation and the Thrive Foundation for Youth."

References

- Bayley, T. C., & Snyder, C. R. (2007). Satisfaction with Life and hope: A look at age and marital status. *The Psychological Record*, 57(2), 223-240.
- Blattner, M. C. C., Liang, B., Lund, T., & Spencer, R. (2013). Searching for a sense of purpose: The role of parents and effects on self-esteem among female adolescents. *Journal of Adolescence*, 36, 839–848. doi:10.1016/j.adolescence.2013.06.008
- Bronk, K. C. (2014). *Purpose in life. A critical component of optimal youth development*, London, England: Springer
- Bronk, K. C. (2011). Portraits of purpose: The role of purpose in identity formation. A special issue on instructing for and supporting youth purpose. *New Directions in Youth Development*, 2011(132), 31–44. doi:10.1002/yd.426.
- Bronk, K. C., Finch, W. H., & Talib, T. L. (2010). Purpose in life among high ability adolescents. *High Ability Studies*, 21(2), 133–145. doi:10.1080/17439760903271439
- Bronk, K. C., & Finch, W. H. (2010). Adolescent characteristics by type of long-term aim in life. *Applied Developmental Science*, 14(1), 35-44. doi:10.1080/10888690903510331
- Bronk, K. C., Hill, P., Lapsley, D., Talib, T. L., & Finch, W. H. (2009). Purpose, hope, and life satisfaction in three age groups. *Journal of Positive Psychology*, 4, 500–510. doi:10.1080/17439760903271439
- Bundick, M. (2011). The benefits of reflecting on and discussing purpose in life in emerging adulthood. *New Directions for Student Leadership*, 132, 89–104. doi:10.1002/yd.430.
- Bundick, M., Andrews, M., Jones, A., Mariano, J. M., Bronk, K. C., & Damon, W. (2006). *Revised youth purpose survey*. Unpublished instrument, Stanford Center on Adolescence, Stanford, CA. Retrieved from <https://coa.stanford.edu/publications/revised-youth-purpose-survey>
- Burrow, A. L., & Hill, P. L. (2011). Purpose as a form of identity capital for positive youth adjustment. *Developmental Psychology*, 47(4), 1196 –1206. doi:10.1037/a0023818

- Burrow, A. L., O'Dell, A. C., & Hill, P. L. (2010). Profiles of a developmental asset: Youth purpose as a context for hope and well-being. *Journal of Youth and Adolescence*, 39(11), 1265–1273. doi:10.1007/s10964-009-9481-1
- Caycho-Rodríguez, T., Ventura-León, J. L., García Cadena, C. H., Barboza-Palomin, M., Arias-Gallegos, W. L., Dominguez-Vergara, J., et al. (2018). Psychometric evidence of the Diener's Satisfaction with Life Scale in Peruvian elderly. *Revista Ciencias de la Salud*, 16(3), 488-506. doi:10.12804/revistas.urosario.edu.co/revsalud/a.7267
- Cazan, A. M. (2014) The Romanian version of the satisfaction with life scale. *Romanian Journal of Experimental Applied Psychology*, 5, 42-47.
- Cheek, J. M., & Briggs, S. R.. (2013) *Aspects of Identity Questionnaire (AIQ-IV)*. Measurement Instrument Database for the Social Science. Retrieved from <http://www.midss.org/content/aspects-identity-questionnaire-aiq-iv>
- Cheek, J. M., Smith, S., & Tropp, L. R. (2002). *Relational identity orientation: a fourth scale for the AIQ*, Conference: Society for Personality and Social Psychology, Annual Meeting, February 2002, Savannah. doi:10.13140/2.1.1643.7763
- Crumbaugh, J. C. (1977). The Seeking of Noetic Goals Test (SONG): A complimentary scale to the Purpose in Life Test (PIL). *Journal of Clinical Psychology*, 33(3), 900–907. doi:10.1002/1097-4679(197707)33:3<900::AID-JCLP2270330362>3.0.CO;2-8
- Crumbaugh, J. C., & Maholick, L. T. (1964). An experimental study in existentialism: The psychometric approach to Frankl's concept of noogenic neurosis. *Journal of Clinical Psychology*, 20(2), 200–207. doi:10.1002/1097-4679(196404)20:2<200::AID-JCLP2270200203>3.0.CO;2-U
- Damon, W. (2008). *The path to purpose: How young people find their calling in life*. New York, US: The Free Press.
- Damon, W., Menon, J., & Bronk, K. C. (2003). The development of purpose during adolescence. *Applied Developmental Science*, 7(3), 119–128. doi:10.1207/S1532480XADS0703_2
- Diener, E., Wirtz, D., Tov, W., Kim-Prieto, C., Choi, D., Oishi, S., & Biswas-Diener, R. (2009). New measures well-being: flourishing and positive and negative feelings. *Social Indicator Research*, 39, 247–266. doi:10.1007/978-90-481-2354-4_12
- Diener, E., Emmons, R. A., Larsen, R. J., & Griffin, S. (1985). The satisfaction with life scale. *Journal of Personality Assessment*, 49(1), 71–75. doi:10.1207/s15327752jpa4901_13
- Douglas, I. (2015). *What makes life meaningful? A study of urban youth and the relationship between prosocial tendencies, civic engagement, and purpose in life*. (Doctoral dissertation, Trinity College, Hartford, CT), Retrieved from <http://digitalrepository.trincoll.edu/theses/466>
- Frankl, V. E. (1959). *Man's search for meaning*. Boston, US: Beacon Press.
- Galanakis, M., Lakioti, A., Pezirkianidis, C., Karakasidou, E., & Stalikas, A. (2017). Reliability and validity of the Satisfaction with Life Scale (SWLS) in a Greek sample. *The International Journal of Humanities & Social Studies*, 5(2), 120-127.
- Hablas, R., & Hutzell, R. (1982). The Life Purpose Questionnaire: An alternative to the Purpose in Life test for geriatric, neuropsychiatric patients. In S. A. Wawrytko (Ed.), *Analecta Frankliana: The proceedings of the First World Congress of Logotherapy: 1980* (pp. 211–215). Berkeley, CA: Strawberry Hill.
- Han, H., Kim, J., Jeong, C., & Cohen, G. L. (2017). Attainable and relevant moral exemplars are more effective than extraordinary exemplars in promoting voluntary service engagement. *Frontiers in Psychology*, 8, 283. doi:10.3389/fpsyg.2017.00283
- Hair, J. F., Jr., Black, W. C., Babin, B. J., & Anderson, R. E. (2014). *Multivariate data analysis*, 7th edition, Essex, England: Pearson Education Limited
- Hardy, S. A., Walker, L. J., Olsen, J. A., Woodbury, R. D., & Hickman, J. R. (2014). Moral identity as moral ideal self: Links to adolescent outcomes. *Developmental Psychology*, 50(1), 45–57. doi:10.1037/a0033598.
- Hayes, S. C., Strosahl, K. D., & Wilson, K. G. (1999). *Acceptance and commitment therapy: An experiential approach to behavior change*. New York, US: Guilford Press.
- Hill, P. L., & Burrow, A. L. (2012). Viewing purpose through an Eriksonian lens. *Identity: An International Journal of Theory and Research*, 12(1), 74–91. doi:10.1080/15283488.2012.632394

- Hill, P. L., Burrow, A. L., Brandenberger, J. W., Lapsley, D. K., & Quaranto, J. C. (2010). Collegiate purpose orientations and well-being in early and middle adulthood. *Journal of Applied Developmental Psychology, 31*(2), 173–179. doi:10.1016/j.appdev.2009.12.001
- Hutzell, R. R. (1989). *Life Purpose Questionnaire overview sheet*. Berkeley, US: Institute of Logotherapy Press.
- Kiang, L., & Fuligni, A. J. (2010). Meaning in life as a mediator of ethnic identity and adjustment among adolescents from Latin, Asian, and European American backgrounds. *Journal of Youth and Adolescence, 39*, 1253–1264. doi:10.1007/s10964-009-9475-z
- Law, B. M. F. (2012). Psychometric properties of the existence subscale of the Purpose in Life questionnaire for Chinese adolescents in Hong Kong. *The Scientific World Journal, 2012*. doi:10.1100/2012/685741
- Li, F., Bai, X., & Wang, Y. (2013) The scale of positive and negative experience (SPANEX): Psychometric properties and normative data in a large Chinese sample, *PLoS One, 8*(4), 1–9. doi:10.1371/journal.pone.0061137
- Lin, C. C. (2015) Validation of the Psychological Well-being Scale for use in Taiwan. *Social Behavior and Personality: An International Journal, 43*(5), 867-874. doi:10.2224/sbp.2015.43.5.867
- López-Ortega, M., Torres-Castro, S., & Rosas-Carrasco, O. (2016). Psychometric properties of the Satisfaction with Life Scale (SWLS): secondary analysis of the Mexican Health and aging study. *Health and Quality of Life Outcomes, 14*(1), 170. doi:10.1186/s12955-016-0573-9
- Luștea, A., Al Ghazi, L., & Predescu, M. (2018) Adapting and validating Ryff's psychological well-being scale on Romanian student population. *Educația 21 Journal, 1*, 117-126. doi:10.24193/ed21.2018.16.15
- Massey, E. K., Gebhardt, W. A., & Garnefski, N. (2008). Adolescent goal content and pursuit: A review of the literature from the past 16 years. *Developmental Review, 28*(4), 421–460. doi:10.1016/j.dr.2008.03.002
- McKnight, P. E., & Kashdan, T.B. (2009), Purpose in life as a system that creates and sustains health and well-being: An integrative, testable theory. *Review of General Psychology, 13*(3), 242-251. doi:10.1037/a0017152
- Moran, S. (2009). Purpose: Giftedness in intrapersonal intelligence. *High Ability Studies, 20*(2), 143–159. doi:10.1080/13598130903358501
- Pavot, W., & Diener, E. (1993). Review of the Satisfaction with Life Scale. *Psychological Assessment, 5*(2), 164–172. doi:10.1037/1040-3590.5.2.164
- Pavot, W., Diener, E., Colvin, C. R., & Sandvik, E. (1991). Further validation of the Satisfaction With Life Scale: Evidence for the cross-method convergence of well-being measures. *Journal of Personality Assessment, 57*(1), 149–161. doi:10.1207/s15327752jpa5701_17
- Reker, G. (1992). *The Life Attitude Profile-Revised (LAP-R). Procedures manual: Research edition*. Peterborough, Canada: Student Psychologists Press.
- Ryan, R. M., & Deci, E. L. (2001). On happiness and human potentials: A review of research on hedonic and eudaimonic well-being. *Annual Review of Psychology, 52*(1), 141–166. doi:10.1146/annurev.psych.52.1.141
- Ryff, C. D., & Singer, B. (1998). The contours of positive human health. *Psychological Inquiry, 9*(1), 1–28. doi:10.1207/s15327965pli0901_1
- Ryff, C. D., & Keyes, C. L. M. (1995). The structure of psychological well-being revisited. *Journal of Personality and Social Psychology, 69*(4), 719–727. doi:10.1037/0022-3514.69.4.719
- Ryff, C. D. (1989). Happiness is everything, or is it? Explorations on the meaning of psychological well-being. *Journal of Personality and Social Psychology, 57*(6), 1069–1081. doi:10.1037/0022-3514.57.6.1069
- Steger, M. F., Frazier, P., Oishi, S., & Kaler, M. (2006). The meaning in life questionnaire: Assessing the presence of and search for meaning in life. *Journal of Counseling Psychology, 53*(1), 80–93. doi:10.1037/0022-0167.53.1.80
- Sumner, R., Burrow, A., & Hill, P.L. (2015). Identity and purpose as predictors of subjective well-being in emerging adulthood. *Emerging adulthood, 3*(1), 46-54. doi:10.1177/2167696814532796
- Villarosa, J.B., & Ganotice, F.A., (2018) Construct Validation of Ryff's Psychological Well-being Scale: Evidence From Filipino Teachers in the Philippines. *Philippine Journal of Psychology, 51*(1), 1-20. doi:10.31710/pjp/0051.01.01

- Yeager, D. S., Bundick, M. J., & Johnson, R. (2012) The role of future work goal motives in adolescent identity development: A longitudinal mixed-methods investigation, *Contemporary Educational Psychology*, 37(3), 206-217. doi.org/10.1016/j.cedpsych.2012.01.004
- Yeager, D. S., & Bundick, M. J. (2009). The role of purposeful work goals in promoting meaning in life and school work during adolescence. *Journal of Adolescent Research*, 24(4), 423–452. doi.org/10.1177/0743558409336749
- Yalom, I. (1980). *Existential psychotherapy*. New York, US: Basic Books.
- Yin, R., & Etilé, F. (2019), *Measuring identity orientations for understanding preferences: A French validation of the Aspects-of-Identity Questionnaire*, Retrieved from <https://halshs.archives-ouvertes.fr/halshs-02057130/document>